



Where Automation Connects.



inRax[®]
ILX34-AENWG
POINT I/O Platform
Wireless Point I/O Adapter

July 31, 2009

SETUP GUIDE

Important User Information

Important: Power must be provided from a limited power source.

Because of the variety of uses for the products described in this publication, those responsible for the application and use of these products must satisfy themselves that all necessary steps have been taken to assure that each application and use meets all performance and safety requirements, including any applicable laws, regulations, codes and standards. In no event will Rockwell Automation be responsible or liable for indirect or consequential damage resulting from the use or application of these products.

Any illustrations, charts, sample programs, and layout examples shown in this publication are intended solely for purposes of example. Since there are many variables and requirements associated with any particular installation, Rockwell Automation does not assume responsibility or liability (to include intellectual property liability) for actual use based upon the examples shown in this publication.

Allen-Bradley publication SGI-1.1, *Safety Guidelines for the Application, Installation and Maintenance of Solid-State Control* (available from your local Rockwell Automation office), describes some important differences between solid-state equipment and electromechanical devices that should be taken into consideration when applying products such as those described in this publication.

Reproduction of the contents of this copyrighted publication, in whole or part, without written permission of Rockwell Automation, is prohibited.

Throughout this publication, notes may be used to make you aware of safety considerations. The following annotations and their accompanying statements help you to identify a potential hazard, avoid a potential hazard, and recognize the consequences of a potential hazard:

Warning: Identifies information about practices or circumstances that can cause an explosion in a hazardous environment, which may lead to personal injury or death, property damage, or economic loss.

Caution: Identifies information about practices or circumstances that can lead to personal injury or death, property damage, or economic loss.

Important: Identifies information that is critical for successful application and understanding of the product.

Burn Hazard: Labels may be located on or inside the equipment (for example, drive or motor) to alert people that surfaces may be dangerous temperatures.

Shock Hazard: Labels may be located on or inside the equipment (for example, drive or motor) to alert people that dangerous voltage may be present.

Environment and Enclosure

Caution: This equipment is intended for use in a Pollution Degree 2 industrial environment, in overvoltage Category II applications (as defined in IEC publication 60664-1), at altitudes up to 2000 meters without derating.

This equipment is considered Group 1, Class A industrial equipment according to IEC/CISPR Publication 11. Without appropriate precautions, there may be potential difficulties ensuring electromagnetic compatibility in other environments due to conducted as well as radiated disturbance.

This equipment is supplied as "open type" equipment. It must be mounted within an enclosure that is suitably designed for those specific environmental conditions that will be present and appropriately designed to prevent personal injury resulting from accessibility to live parts. The interior of the enclosure must be accessible only by the use of a tool. Subsequent sections of this publication may contain additional information regarding specific enclosure type ratings that are required to comply with certain product safety certifications.

See NEMA Standards publication 250 and IEC publication 60529, as applicable, for explanations of the degrees of protection provided by different types of enclosure. Also, see the appropriate sections in this publication, as well as the Allen-Bradley publication 1770-4.1 ("Industrial Automation Wiring and Grounding Guidelines"), for additional installation requirements pertaining to this equipment.

Caution: Preventing Electrostatic Discharge

- This equipment is sensitive to electrostatic discharge, which can cause internal damage and affect normal operation. Follow these guidelines when you handle this equipment:
- Touch a grounded object to discharge potential static.
- Wear an approved grounding wriststrap.
- Do not touch connectors or pins on component boards.

- Do not touch circuit components inside the equipment.
- If available, use a static-safe workstation.
- When not in use, store the equipment in appropriate static-safe packaging.

Caution: POINT I/O is grounded through the DIN-rail to chassis ground. Use zinc-plated, yellow-chromated steel DIN-rail to assure proper grounding. Using other DIN-rail materials (for example, aluminum, plastic, and so on) which can corrode, oxidize or are poor conductors, can result in improper or intermittent platform grounding.

Caution: When you connect or disconnect the Removable Terminal Block (RTB) with field side power applied, an electrical arc can occur. This could cause an explosion in hazardous location installations.

Be sure that power is removed or the area is nonhazardous before proceeding.

Important Installation Instructions: Radio Modules

The following Information and warnings pertaining to the radio module must be heeded:

- A "THIS DEVICE CONTAINS A TRANSMITTER MODULE, FCC ID: R68MTCHDRCT. PLEASE SEE FCC ID LABEL ON BACK OF DEVICE."
- B "THIS DEVICE USES AN INTERNAL COMPACT FLASH RADIO MODULE AS THE PRIMARY RADIO COMPONENT. THE COMPACT FLASH RADIO MODULE DOES NOT HAVE AN FCC ID LABEL. THE COMPACT FLASH RADIO MODULE HAS NO USER SERVICABLE PARTS."
- C "THIS DEVICE COMPLIES WITH PART 15 OF THE FCC RULES. OPERATION IS SUBJECT TO THE FOLLOWING TWO CONDITIONS: (1) THIS DEVICE MAY NOT CAUSE HARMFUL INTERFERENCE, AND (2) THIS DEVICE MUST ACCEPT ANY INTERFERENCE RECEIVED, INCLUDING INTERFERENCE THAT MAY CAUSE UNDESIRE OPERATION."
- D "THIS DEVICE AND ANY RADIO ACCESSORY SOLD BY PROSOFT MUST BE INSTALLED BY AN AUTHORIZED PROFESSIONAL INDUSTRIAL RADIO SYSTEM INTEGRATOR. FURTHER, ONLY RADIO ACCESSORIES SOLD BY PROSOFT AND SPECIFICALLY TESTED FOR USE WITH THIS DEVICE MAY BE USED WITH THIS DEVICE."
- E "THE USER OF THIS EQUIPMENT CANNOT BE WITHIN 20 cm. FROM THE RADIATING ELEMENT DEVICE."
- F "CHANGES OR MODIFICATIONS NOT EXPRESSLY APPROVED BY THE PARTY RESPONSIBLE FOR COMPLIANCE COULD VOID THE USER'S AUTHORITY TO OPERATE THE EQUIPMENT."

Industry Canada Requirements:

- A "THIS DEVICE HAS BEEN DESIGNED TO OPERATE WITH AN ANTENNA HAVING A MAXIMUM GAIN OF 24 dB. AN ANTENNA HAVING A HIGHER GAIN IS STRICTLY PROHIBITED PER REGULATIONS OF INDUSTRY CANADA. THE REQUIRED ANTENNA IMPEDANCE IS 50 OHMS."
- B "TO REDUCE POTENTIAL RADIO INTERFERENCE TO OTHER USERS, THE ANTENNA TYPE AND ITS GAIN SHOULD BE CHOSEN SUCH THAT THE EQUIVALENT ISOTROPICALLY RADIATED POWER (EIRP) IS NOT MORE THAN THAT REQUIRED FOR SUCCESSFUL COMMUNICATION."
- C "THE INSTALLER OF THIS RADIO EQUIPMENT MUST INSURE THAT THE ANTENNA IS LOCATED OR POINTED SUCH THAT IT DOES NOT EMIT RF FIELD IN EXCESS OF HEALTH CANADA LIMITS FOR THE GENERAL POPULATION; CONSULT SAFETY CODE 6, OBTAINABLE FROM HEALTH CANADA."

WARNING:

This is a Class A product. In a domestic environment this product may cause radio interference in which case the user may be required to take adequate measures.

Agency Approval & Certification



Wireless Approvals

Visit our website at www.prosoft-technology.com for current wireless approval information.

European Hazardous Location Approval

European Zone 2 Certification (The following applies when the product bears the EEx Marking)

This equipment is intended for use in potentially explosive atmospheres as defined by European Union Directive 94/9/EC.

The ATEX test report certifies that this equipment has been found to comply with the Essential Health and Safety Requirements relating to the design and construction of Category 3 equipment intended for use in potentially explosive atmospheres, given in Annex II to this Directive. The examination and test results are recorded in a confidential report.

Compliance with the Essential Health and Safety Requirements has been assured by compliance with EN 60079-0 and EN60079-15.

Important: Observe the following additional Div 2 certification requirements.

- This equipment is not resistant to sunlight or other sources of UV radiation.
- The secondary of a current transformer shall not be open-circuited when applied in Class I, Div 2 environments.
- Equipment of lesser Enclosure Type Rating must be installed in an enclosure providing at least IP54 protection when applied in Class I, Div 2 environments.
- This equipment shall be used within its specified ratings defined by Allen-Bradley.
- Provision shall be made to prevent the rated voltage from being exceeded by transient disturbances of more than 40% when applied in Class I, Div 2 environments.

North American Hazardous Location Approval

The following information applies when operating this equipment in hazardous locations:

Products marked "CL I, DIV 2, GP A, B, C, D" are suitable for use in Class I Division 2 Groups A, B, C, D, Hazardous Locations and nonhazardous locations only. Each product is supplied with markings on the rating nameplate indicating the hazardous location temperature code. When combining products within a system, the most adverse temperature code (lowest "T" number) may be used to help determine the overall temperature code of the system. Combinations of equipment in your system are subject to investigation by the local Authority Having Jurisdiction at the time of installation.

Warning: EXPLOSION HAZARD -

Do not disconnect equipment unless power has been removed or the area is known to be nonhazardous.

Do not disconnect connections to this equipment unless power has been removed or the area is known to be nonhazardous. Secure any external connections that mate to this equipment by using screws, sliding latches, threaded connectors, or other means provided with this product.

Substitution of components may impair suitability for Class I, Division 2.

If this product contains batteries, they must only be changed in an area known to be nonhazardous.

Informations sur l'utilisation de cet équipement en environnements dangereux:

Les produits marqués "CL I, DIV 2, GP A, B, C, D" ne conviennent qu'à une utilisation en environnements de Classe I Division 2 Groupes A, B, C, D dangereux et non dangereux. Chaque produit est livré avec des marquages sur sa plaque d'identification qui indiquent le code de température pour les environnements dangereux. Lorsque plusieurs produits sont combinés dans un système, le code de température le plus défavorable (code de température le plus faible) peut être utilisé pour déterminer le code de température global du système. Les combinaisons d'équipements dans le système sont sujettes à inspection par les autorités locales qualifiées au moment de l'installation.

Avertissement: RISQUE D'EXPLOSION –

Couper le courant ou s'assurer que l'environnement est classé non dangereux avant de débrancher l'équipement.

Couper le courant ou s'assurer que l'environnement est classé non dangereux avant de débrancher les connecteurs. Fixer tous les connecteurs externes reliés à cet équipement à l'aide de vis, loquets coulissants, connecteurs filetés ou autres moyens fournis avec ce produit.

La substitution de composants peut rendre cet équipement inadapté à une utilisation en environnement de Classe 1, Division 2.

S'assurer que l'environnement est classé non dangereux avant de changer les piles.

Your Feedback Please

We always want you to feel that you made the right decision to use our products. If you have suggestions, comments, compliments or complaints about the product, documentation, or support, please write or call us.

ProSoft Technology

5201 Truxtun Ave., 3rd Floor

Bakersfield, CA 93309

+1 (661) 716-5100

+1 (661) 716-5101 (Fax)

www.prosoft-technology.com

Copyright © ProSoft Technology, Inc. 2009. All Rights Reserved.

ILX34-AENWG Setup Guide

July 31, 2009

ProSoft Technology[®], ProLinX[®], inRAX[®], ProTalk[®], and RadioLinX[®] are Registered Trademarks of ProSoft Technology, Inc. All other brand or product names are or may be trademarks of, and are used to identify products and services of, their respective owners.

ProSoft Technology[®] Product Documentation

In an effort to conserve paper, ProSoft Technology no longer includes printed manuals with our product shipments. User Manuals, Datasheets, Sample Ladder Files, and Configuration Files are provided on the enclosed CD-ROM, and are available at no charge from our web site: www.prosoft-technology.com

Printed documentation is available for purchase. Contact ProSoft Technology for pricing and availability.

North America: +1.661.716.5100

Asia Pacific: +603.7724.2080

Europe, Middle East, Africa: +33 (0) 5.3436.87.20

Latin America: +1.281.298.9109

Contents

Important User Information	2
Important Installation Instructions: Radio Modules	3
Agency Approval & Certification	3
European Hazardous Location Approval	4
North American Hazardous Location Approval.....	4
Your Feedback Please.....	5
ProSoft Technology® Product Documentation	5
1 Scope	9
1.1 Learning Objectives.....	9
1.2 ProSoft Technology Documentation	9
1.3 Prerequisites	10
2 About the Example Applications	13
2.1 System Components	14
2.2 Set Up the Hardware.....	14
3 Procedures	15
3.1 Install the Configuration Tools.....	15
3.2 Physical Setup.....	16
3.3 Verify Communication	55
4 Conclusion	57
4.1 How to Get Help	57
4.2 Frequently Asked Questions	58
5 Glossary of Terms	61
Index	77

1 Scope

In This Chapter

❖ Learning Objectives.....	9
❖ ProSoft Technology Documentation.....	9
❖ Prerequisites	10

This document acts as a tutorial in providing step-by-step instructions on how to send and receive data wirelessly from a controller to a POINT I/O network using the ILX34-AENWG adapter.

1.1 Learning Objectives

When you have completed all the steps in this Setup Guide, you will have learned how to

- Understand how the sample application works (page 13)
- Install the ILX34-AENWG adapter (page 16)
- Install the Add-On Profile for the adapter (page 37, page 15)
- Configure the Wireless Point I/O Adapter (page 27)
- Verify the ILX34-AENWG communication status (page 41)

1.2 ProSoft Technology Documentation

ProSoft Technology provides the following documentation (manuals) with your ILX34-AENWG.

Electronic documentation (on the ILX34-AENWG CD-ROM)

- **Setup Guide: (this manual)** Describes the sample application, and takes you through the steps necessary to install, configure, and verify the correct operation of the adapter
- **User Manual:** Detailed reference guide to the adapter, configuration, functional overview, diagnostics and troubleshooting procedures, and product specifications
- **Datasheet:** Brief description of the adapter's hardware and protocol implementation, general and functional specifications

Additional documentation, tools, and product support

- **Email Technical Support:** Send your support questions to Support@prosoft-technology.com
- **Web Site Support:** Visit the ProSoft Technology web site at www.prosoft-technology.com to download additional documentation, tools and application information
- **Telephone Support:** Please call ProSoft Technology Technical Support at: (Country Code 1+) 661-716-5100. Support is available 24 hours a day, 7 days a week. ProSoft Technology telephone support is free and unlimited

1.3 Prerequisites

To get the most benefit from this setup guide, you should have the following skills:

- **Rockwell Automation® RSLogix 5000™ software:** launch the program, load the Add-On Profile, and configure the project.
- **Microsoft Windows:** install and launch programs, execute menu commands, navigate dialog boxes and enter data.
- **Ethernet networking:** connect the ILX34-AENWG adapter to an Ethernet network using a valid IP address and subnet mask
- **Wireless networking:** correctly configure the adapter to communicate on an 802.11b/g wireless network
- **Hardware installation and wiring:** install the adapter and safely connect POINT I/O devices to the ILX34-AENWG adapter's chassis

1.3.1 System Requirements

The ILX34-AENWG adapter requires the following minimum hardware and software components:

- Rockwell Automation® processor, with compatible power supply
 - ControlLogix™ 1756-L6x (firmware version 17.03 or higher), or 1756-6xS (firmware version 17.07 or higher)
 - or
 - CompactLogix™ 1769-L32E or 1769-L35E, (firmware version 17.04 or higher)
- Rockwell Automation RSLogix 5000 programming software version 16 or higher. Version 17 is required if you wish to use the ILX34-AENWG Add-On Profile.
- Rockwell Automation RSLinx communication software version 2.54 or higher
- An 802.11g Radio. ProSoft recommends the RLXIB-IHW 802.11 a/b/g Industrial Hotspot (page 18).
- If you plan to use the ILX34-AENWG with a 1756-ENBT module or 1768-ENBT module, note the following firmware version requirements:
 - 1756-ENBT firmware revision 4.007 or later
 - 1768-ENBT firmware revision 2.003 or later
 - Use BootP revision 2.3.2 or later to assign IP addresses to the adapter.

- Pentium® II 450 MHz minimum. Pentium III 733 MHz (or better) recommended
- Supported operating systems:
 - Microsoft Windows Vista
 - Microsoft Windows XP Professional with Service Pack 1 or 2
 - Microsoft Windows 2000 Professional with Service Pack 1, 2, or 3
 - Microsoft Windows Server 2003
- 128 Mbytes of RAM minimum, 256 Mbytes of RAM recommended
- Microsoft Windows Explorer version 7
- 256-color VGA graphics adapter, 800 x 600 minimum resolution (True Color 1024 × 768 recommended)
- CD-ROM drive

Note: The Hardware and Operating System requirements in this list are the minimum recommended to install and run software provided by ProSoft Technology. Other third party applications may have different minimum requirements. Refer to the documentation for any third party applications for system requirements.

2 About the Example Applications

In This Chapter

- ❖ System Components 14
- ❖ Set Up the Hardware 14

The following topics describe two example applications that demonstrate the procedures for configuring and communicating with POINT I/O modules using the ILX34-AENWG adapter. Use these example applications as building blocks to help you get your own system up and running. We recommend that you set up and run the example applications and use them as guides.

The following illustration shows the type of system you will be setting up.

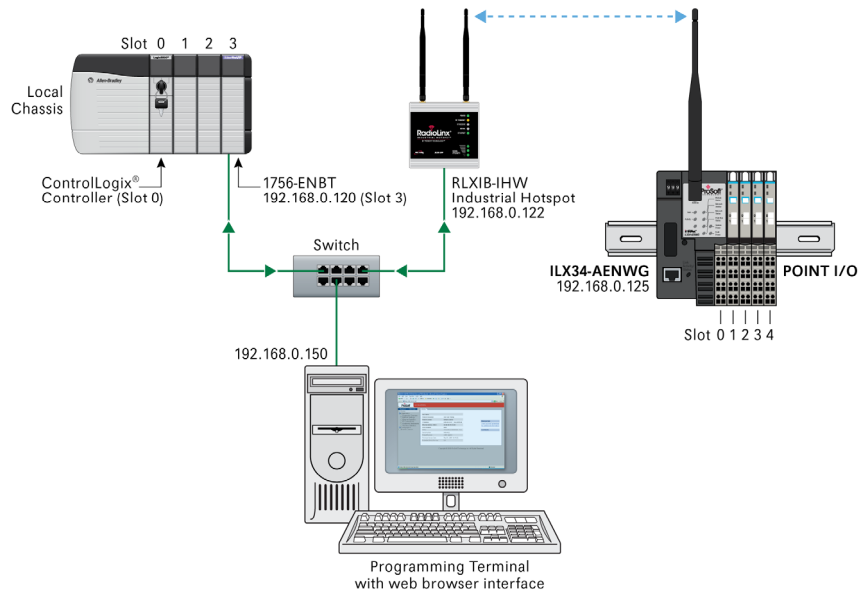

Note: During the installation, you must connect to the ILX34-AENWG directly via Ethernet to set its wireless settings so it can communicate with its Access Point. To prevent a loop from occurring, avoid connecting Ethernet cables to the Access Point and the ILX34-AENWG at the same time after the wireless link is established.

2.1 System Components

We used the following components for the example applications. You need the same or similar components to set up your own control system using POINT I/O modules on an EtherNet/IP network.

Quantity	Product Name	Catalog Number
Hardware		
1	Wireless Point I/O Adapter	ILX34-AENWG
1	POINT I/O 24V dc sink output module	1734-OV4E/C
1	POINT I/O relay output module	1734-OW2/C
1	DIN rail	199-DR1 or equivalent
1	ControlLogix chassis	1756-A4, (or 1756-A7, 1756-A13,1756-A17)
1	ControlLogix power supply	1756-PA72, (or 1756-PB72)
1	ControlLogix controller	1756-L5* with firmware version 17
1	ControlLogix EtherNet/IP bridge module	1756-ENBT with firmware version 4.007 or higher
1	RadioLinX Industrial Hotspot	RLXIB-IHW
1	Personal computer that supports RSLogix 5000 software	Any appropriate model running Windows NT 4.0, Service Pack 6A or higher
1	Ethernet switch	Refer to manufacturer's specifications
1	24V dc power supply	
Associated media and connectors as needed		
Software		
1	RSLinx communications software, version 2.54.00 or later	9355-WAB, 9355-WABOEM, 9355-WABC
1	RSLogix 5000 programming software, version 17 or later	9324-RLD300ENE

2.2 Set Up the Hardware

In these examples, a ControlLogix chassis contains the Logix controller in slot 0, and a 1756-ENBT bridge module in slot 3. We mounted the ILX34-AENWG adapter on a DIN rail in slot 0, with a 1734-OW2/C relay output module in slot 1, a 1734-OV4E/C sink output module in slot 2, and a 24 volt DC power supply.

To work along with this example, set up your system as follows.

- Note that the example application, the Logix controller and 1756-ENBT module (firmware revision 4.007 or later) uses the slots shown in the illustration (page 13).
- Verify the IP addresses for your programming terminal, 1756-ENBT module, and ILX34-AENWG adapter.
- Verify the position (slot) of the I/O modules on the DIN rail.
- Verify that you have properly connected all wiring and cabling.
- You must configure your communication driver (such as AB_ETH-1 or AB-ETHIP-1) in RSLinx software, as described in the User Manual.

3 Procedures

In This Chapter

- ❖ Install the Configuration Tools 15
- ❖ Physical Setup 16
- ❖ Verify Communication 55

3.1 Install the Configuration Tools

3.1.1 Install the ILX34-AENWG Add-On Profile

- 1 Verify that your computer meets the hardware and operating system requirements. (page 10)

Important: You must have "Administrator" rights on your computer to install this application.

- 2 Insert the ProSoft Solutions CD-ROM in an available CD-ROM drive in your computer.
- 3 On most computers, the installation program will start automatically within a few seconds. If the installation does not start automatically on your computer, click the **START** button, choose **RUN**, and then type `explorer`. Click **OK** to start Windows Explorer. In Windows Explorer, open the **MY COMPUTER** icon and navigate to the CD-ROM drive.
- 4 Navigate to the folder containing the ILX34-AENWG Add-On Profile, and then double-click the file **SETUP.EXE**. This action starts the installation wizard.
- 5 Follow the instructions on the installation wizard to install the program.
- 6 Click **FINISH** to complete the installation. If you are prompted to restart your computer, save your work in any applications that are running, close the applications, and allow the computer to restart.

3.2 Physical Setup

3.2.1 Adapter Components

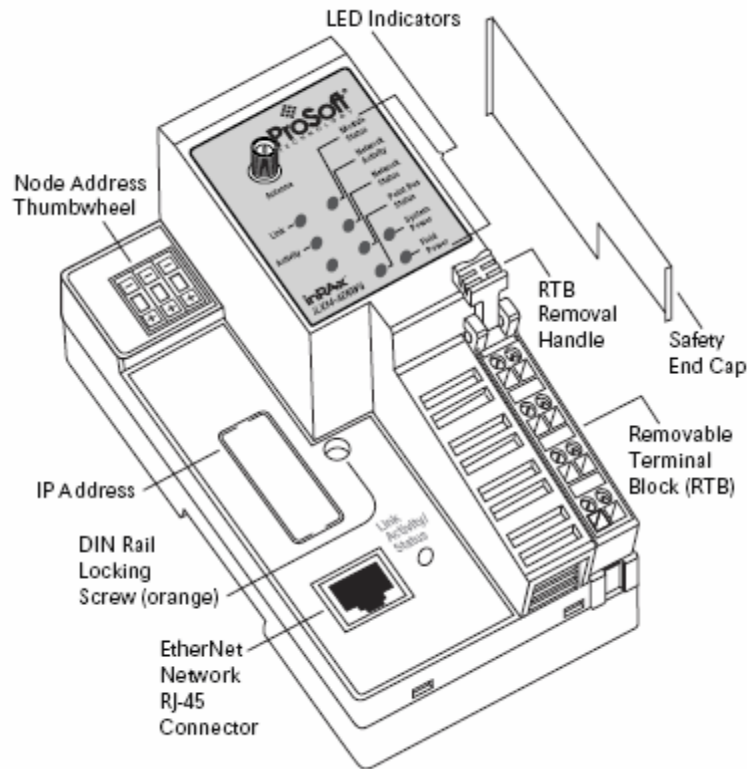

The Wireless Point I/O Adapter is a communications adapter for POINT I/O modules. The adapter provides an interface for controlling and communicating with POINT I/O modules from an Ethernet network.

3.2.2 Install the Wireless Point I/O Adapter on the DIN-rail

Warning: You must follow all safety instructions when installing this or any other electronic devices. Failure to follow safety procedures could result in damage to hardware or data, or even serious injury or death to personnel. Refer to the documentation for each device you plan to connect to verify that suitable safety procedures are in place before installing or servicing the device.

- 1 Position the adapter vertically above the DIN-rail.
- 2 Press down firmly to install the adapter on the DIN-rail, and then turn the orange screw to lock the adaptor onto the DIN-rail.

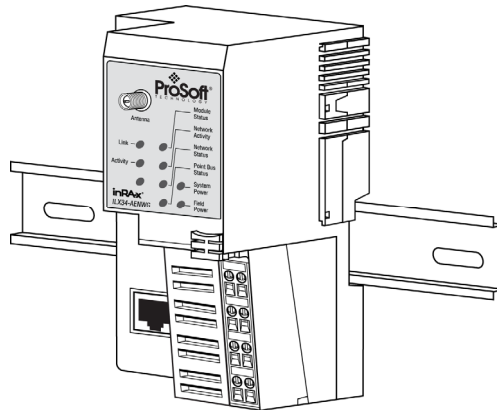

Warning: If you connect or disconnect the Ethernet cable with power applied to this module or any device on the network, an electrical arc can occur. This could cause an explosion in hazardous location installations.

Be sure that power is removed or the area is nonhazardous before proceeding.

- 3 Slide the safety end cap up to remove. This exposes the backplane and power interconnections.

Caution: Do not discard the end cap. Use this end cap to cover the exposed interconnections on the last mounting base on the DIN-rail. Failure to do so could result in equipment damage or injury from electric shock.

Important: You must use series C POINT I/O modules with the ILX34-AENWG adapter. Series A or B POINT I/O modules will not work with this adapter.

3.2.3 Configure the Wireless Access Point

Although the ILX34-AENWG can communicate with any 802.11b/g Access Point radio, ProSoft Technology recommends the RadioLinX series Industrial Broadband radios wherever performance and compatibility are required.

The following configuration steps are for the RLXIB-IHW. Use the examples in these steps to configure your own Access Point to work with the ILX34-AENWG.

Configure the Master Radio (Required)

The following illustration shows an example configuration for a RadioLinX Industrial Hotspot (Access Point) configured as a Master radio.

Note: The radio in this illustration is capable of transmitting at 5 GHz (802.11a) as well as 2.4 GHz (802.11b/g). The radio in the ILX34-AENWG adapter supports only 2.4 GHz (802.11b/g).

The screenshot displays the configuration interface for a RadioLinX Industrial Hotspot. The top section shows status information: Radio Name: Master, Radio MAC: 00.0D.8D.F0.1F.69, Signal Strength: Master, Parent MAC: none, Firmware: IB3_454, Branch Length: 1, Update every: 5 sec, # Radios Linked: 0, Up Time: 0 Day 0 Hr. 31 Min. 57 Sec., Link Time: n/a. Below this are three main configuration panels: 1. Radio Network Settings: Radio Name: Master, Network SSID: Point_IO, Channel: 8 (2447MHz), Mode: Master (selected), Parent Link: Parent Auto Select (Auto selected), Client MAC: 00.00.00.00.00.00. 2. Security Settings: Encryption: WPA/WPA2-AES, WPA phrase: *****, WEP key: *****, MAC Filter: unchecked, Hide Network SSID: unchecked. 3. Radio Access Settings: Obtain IP address - DHCP: unselected, Use the following IP address: selected, IP Address: 192.168.1.243, Subnet Mask: 255.255.255.0, Def. Gateway: 192.168.1.5, Primary DNS: 0.0.0.0, Secondary DNS: 0.0.0.0. At the bottom are buttons for Apply Changes, Cancel Changes, Factory Defaults, and Help.

In particular, note the following settings.

- **Network SSID:** All radios on the network must use the same Network SSID. In this example, the Network SSID is "Point_IO".
- **Channel:** All radios must use the same channel. In this example, the channel is 8 (2447MHz).
- **Encryption:** All radios must use the same encryption settings. In this example, the encryption type is WPA/WPA2-AES.
- **Passphrase:** All radios must use the same passphrase. For security reasons, the passphrase field is replaced with asterisks. Make a note of the passphrase before configuring additional radios.

Important: Take care to enter the passphrase on the ILX34-AENWG exactly as you entered it in the Master radio.

- **IP Address:** The IP address for all radios must be within the same subnet, and each radio requires its own unique IP address. You can assign static IP addresses, as in this example, or you can use DHCP (Dynamic Host Control Protocol) to manage and assign IP addresses automatically.

Note: Refer to the documentation for your radio (for example, the *RLXIB-IHW User Manual*) for specific steps to configure the settings in this example.

Configure One or More Repeaters (Optional)

The following illustration shows an example configuration for a RadioLinX Industrial Hotspot (Access Point) configured as a Repeater radio. The need for repeater radios is determined by the distance between the Master radio and the ILX34-AENWG, as well as any topographical factors such as hills or other obstructions, which could prevent a clear line-of-sight signal path.

Note: The radio in this illustration is capable of transmitting at 5 GHz (802.11a) as well as 2.4 GHz (802.11b/g). The radio in the ILX34-AENWG adapter supports only 2.4 GHz (802.11b/g).

The screenshot displays the configuration interface for a RadioLinX Industrial Hotspot (802.11abg). The interface is divided into three main sections: Radio Network Settings, Security Settings, and Radio Access Settings. At the top, the status bar shows the radio name 'Repeater', MAC address '00.0D.8D.F0.12.C3', and signal strength '-39dBm, 48SN'. The Radio Network Settings section includes fields for Radio Name (Repeater), Network SSID (Point_IO), and a radio type selector (Repeater selected). The Security Settings section shows encryption set to WPA/WPA2-AES with a WPA phrase and WEP key. The Radio Access Settings section has 'Use the following IP address' selected, with IP Address set to 192.168.1.249, Subnet Mask 255.255.255.0, and Def. Gateway 192.168.1.50. Buttons for 'Apply Changes', 'Cancel Changes', 'Factory Defaults', and 'Help' are at the bottom.

In particular, note the following settings.

- **Network SSID, Channel, Encryption and Passphrase** for the Repeater radio must match those configured for the Master radio and the ILX34-AENWG.
- **IP Address:** The IP address for all radios must be within the same subnet, and each radio requires its own unique IP address. You can assign static IP addresses, as in this example, or you can use DHCP (Dynamic Host Control Protocol) to manage and assign IP addresses automatically.

Note: Refer to the documentation for your radio (for example, the *RLXIB-IHW User Manual*) for specific steps to configure the settings in this example.

3.2.4 Configure the IP Address with the Thumbwheel Switches

Before you can connect to the ILX34-AENWG for the first time, you must configure its IP address.

The simplest way to set the IP address for your initial connection is to use the thumbwheel switches on the front of the adapter.

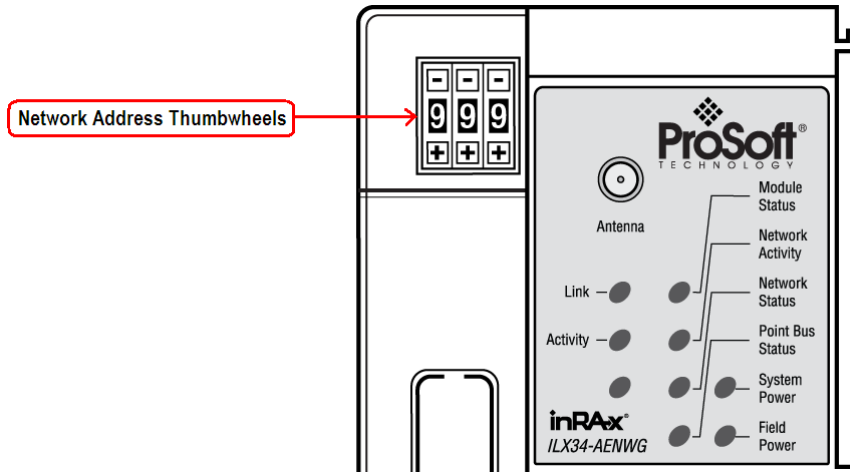

The three thumbwheel switches represent the final octet for the private IP address 192.168.1.xxx (where xxx represents the number set on the switches).

The factory default switch setting is 999. Use the buttons above and below each number to select a temporary IP address to use. Choose a number between 001 and 254, taking care not to duplicate the IP address of any other device on the network.

If you set the switches to an invalid number (that is, 000 or a value greater than 254), the adapter checks to see if you enabled DHCP, according to the following table.

If DHCP is	Then the adapter
Enabled	Asks for an address from a DHCP server. The DHCP server also assigns other Transport Control Protocol (TCP) parameters.
Not enabled	Uses the IP address (along with other TCP configurable parameters) stored in nonvolatile memory

The updated IP address will take effect when the adapter is powered up.

Important: If you set the thumbwheels on the ILX34-AENWG adapter to the value 888 and then power cycle the adapter, the following occurs:

- The DHCP Enabled function is enabled (set to True).
- The Ethernet link is negotiated automatically. The Auto Negotiate function is set to True.
- The Web server is enabled.
- The password for this page resets to the factory default of "password".

Make a note of the value of the switches before you change them, so you can restore those values after resetting the adapter.

3.2.5 Connect Power to the Adapter

The ILX34-AENWG adapter requires an external source of DC voltage. The DC source voltage should be 24V nominal, with a range of 10V to 28.8V. Refer to the following illustrations for wiring information.

Caution: Do not connect 120/240V ac power to this supply.
Warning: If you connect or disconnect wiring while the field-side power is on, an electrical arc can occur. This could cause an explosion in hazardous location installations.
 Be sure that power is removed or the area is nonhazardous before proceeding.

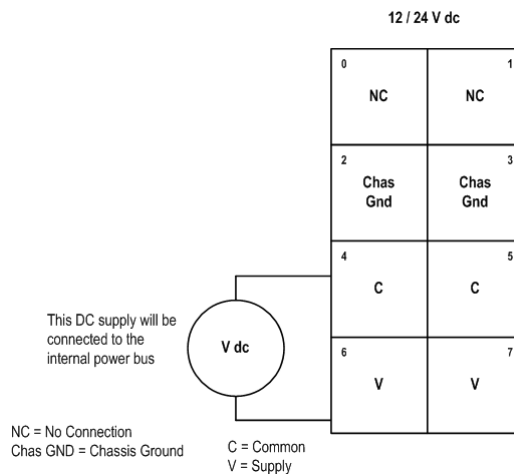
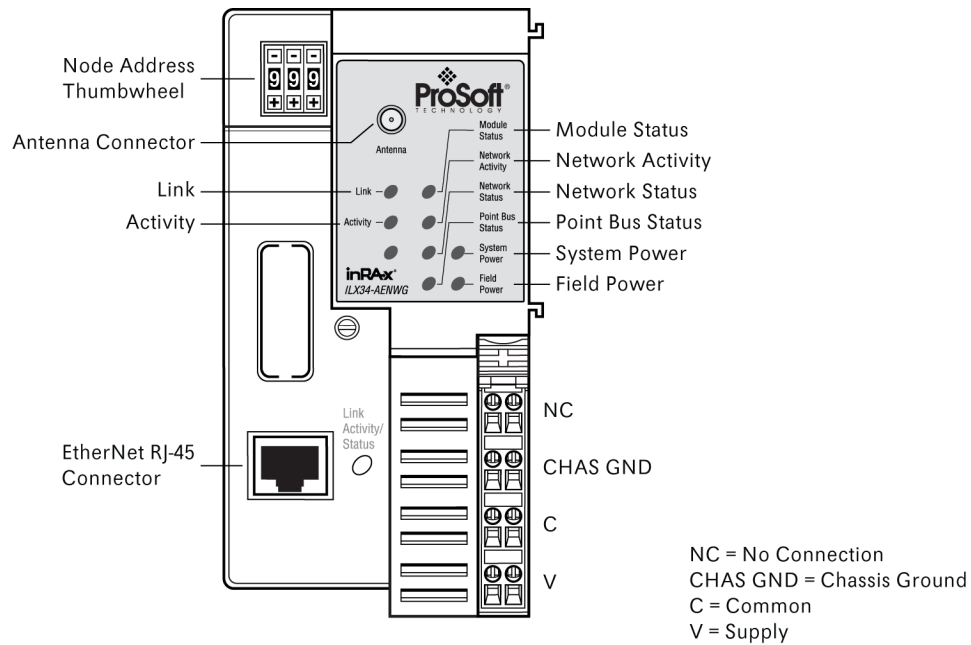

When you power up the POINT I/O for the first time, the adapter must assign addresses to every module in the backplane. POINT I/O modules are all initially configured at the same address.

When you first apply power, all but one module on the backplane should show a solid red Module Status LED.

One by one, the adapter resets these modules and assigns addresses. The amount of time that this operation takes depends on the size of your POINT I/O system.

3.2.6 Connect the Adapter to the EtherNet/IP Network

Connect an Ethernet cable between the adapter's Ethernet port, and the EtherNet/IP network.

Note: This connection is temporary, and is helpful during configuration. You will disconnect the Ethernet cable after you have finished configuring the adapter for wireless communication.

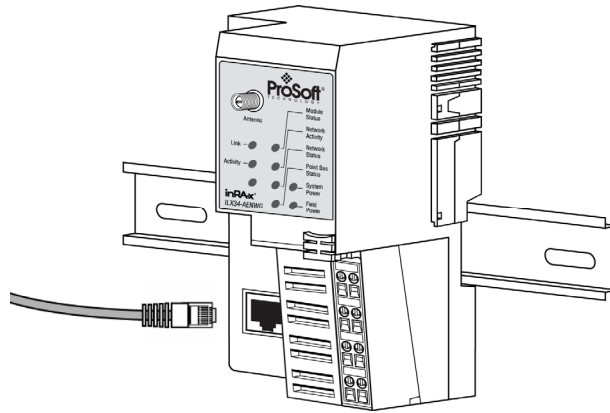

3.2.7 Configure the ILX34-AENWG for Wireless Access

You can configure the ILX34-AENWG's wireless settings from the **MODULE PROPERTIES** dialog box in RSLogix 5000, or from the ILX34-AENWG's web page. The first time you configure the adaptor, you should use the adaptor's web page.

Important: The wireless settings for the ILX34-AENWG must be compatible with the Industrial Hotspot radio (page 18) connected to the Ethernet bridge (for example, a 1756-ENBT module in a ControlLogix rack).

Important: All radios on the network must use the same settings, otherwise they will be unable to communicate with each other.

Configuring Wireless Settings from the Adapter's Web Page

You can monitor and update ILX34-AENWG configuration from the adaptor's built-in web server.

Open your web browser (for example, Microsoft Internet Explorer or Firefox), and connect to the adaptor's temporary network address.

http://192.168.1.xxx

(where xxx is the value you entered in the rotary switches on the front of the adaptor.)

Important: Your PC must be on the same TCP/IP subnet as the adaptor to view these pages.

Important: You must prefix the numeric IP address with "http://", otherwise the web browser may not be able to interpret the address.

The adapter's home page consists of a tree view in the left pane for navigation, and an information pane in the middle. The right column contains links for additional resources and information.

- To view the contents of a folder, click the **EXPAND** button.
- To select a page to view, click the page title in the tree view.

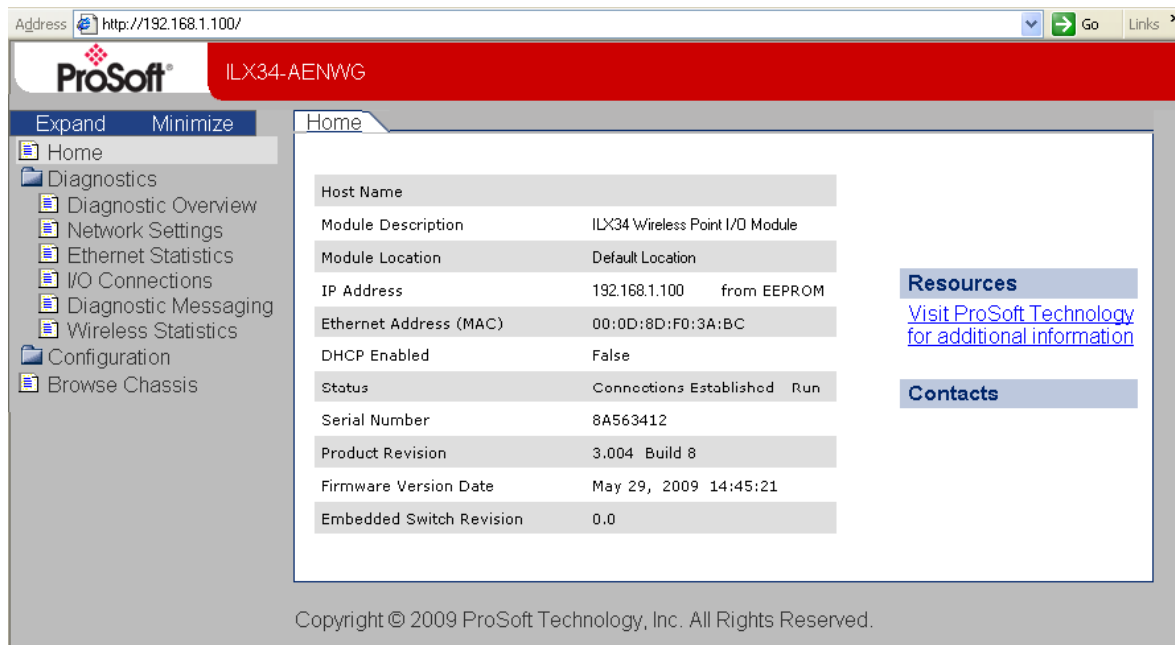

If you are unable to connect to the adapter's web page, verify that your PC is correctly configured to reach IP addresses on the subnet where your adapter communicates.

The **WIRELESS SETTINGS** page opens when you select the **CONFIGURATION** folder in the menu on the left side of the page, and then click the **WIRELESS SETTINGS** link. Use this page to configure the radio settings for the adapter.

Important: The values on this page are in non-volatile memory. Changes to these parameters do not take effect until you reset or cycle power to the ILX34-AENWG adapter.

Field	Description
SSID	Assign a network name (SSID) of up to 32 characters. The radio uses this name in all network references. All radios in a network must have the same SSID. SSID names are case-sensitive.
Encryption Type	<p>Choose the method by which the adapter will apply encryption security:</p> <ul style="list-style-type: none"> ▪ NONE (not recommended) ▪ WEP128 - Legacy security setting using a 128-bit key and WEP encryption. ▪ WPA2/AES (Preferred) - Security setting using WPA (pre-shared key) authentication and AES encryption. <p>The preferred encryption type is AES (Advanced Encryption Standard). You should only select WEP (wired equivalency protocol) for use with an older client radio that only has WEP encryption.</p> <p>WEP is the original security protocol used by 802.11 networks, but AES offers better protection against attacks, for several reasons: AES uses an advanced encryption algorithm that is not susceptible to the same weaknesses as WEP, it performs dynamic key management by changing the session keys frequently, and it performs message integrity checks to prevent forgery and replay.</p> <p>You can also select WEP 128, or None (no encryption) as the encryption type, but none of these settings are recommended.</p>

Field	Description																
WPA Passphrase	To use WPA2/AES encryption on packets sent between the radios, enter a WPA2/AES pass phrase of between eight and 63 normal keyboard characters. This phrase automatically generates an encryption key of 128 hexadecimal characters. This field is only available if you select WPA2/AES as the encryption type.																
WEP Key Index	If using WEP128 encryption, select the Key Index that matches the Key Index used in the Access Point.																
WEP Keys (1-4)	If using WEP128 encryption, enter the WEP Keys that match the Keys in the Access Point.																
Transmit Data Rate	The recommended The ILX34-AENWG supports the following transmit data rates. The default value is Auto: Max 54 Mbps, and this is the recommended value for most applications. <table border="0" style="margin-left: 40px;"> <tr> <td>1 Mbps</td> <td>Auto: Max. 1 Mbps</td> </tr> <tr> <td>2 Mbps</td> <td>Auto: Max. 2 Mbps</td> </tr> <tr> <td>5.5 Mbps</td> <td>Auto: Max. 5.5 Mbps</td> </tr> <tr> <td>11 Mbps</td> <td>Auto: Max. 11 Mbps</td> </tr> <tr> <td>18 Mbps</td> <td>Auto: Max. 18 Mbps</td> </tr> <tr> <td>24 Mbps</td> <td>Auto: Max. 24 Mbps</td> </tr> <tr> <td>36 Mbps</td> <td>Auto: Max. 36 Mbps</td> </tr> <tr> <td>54 Mbps</td> <td>Auto: Max. 54 Mbps</td> </tr> </table>	1 Mbps	Auto: Max. 1 Mbps	2 Mbps	Auto: Max. 2 Mbps	5.5 Mbps	Auto: Max. 5.5 Mbps	11 Mbps	Auto: Max. 11 Mbps	18 Mbps	Auto: Max. 18 Mbps	24 Mbps	Auto: Max. 24 Mbps	36 Mbps	Auto: Max. 36 Mbps	54 Mbps	Auto: Max. 54 Mbps
1 Mbps	Auto: Max. 1 Mbps																
2 Mbps	Auto: Max. 2 Mbps																
5.5 Mbps	Auto: Max. 5.5 Mbps																
11 Mbps	Auto: Max. 11 Mbps																
18 Mbps	Auto: Max. 18 Mbps																
24 Mbps	Auto: Max. 24 Mbps																
36 Mbps	Auto: Max. 36 Mbps																
54 Mbps	Auto: Max. 54 Mbps																

Verify Wireless Communication

At this point, with the Ethernet cable still attached to the ILX34-AENWG, go to the **WIRELESS STATISTICS** web page, and verify that the ILX34-AENWG is linked to the Access Point.

After the link is established, you should disconnect the Ethernet cable from the ILX34 and reconnect it to the Access Point. From this point on, all communications can be done wirelessly.

Note: If Ethernet cables are connected to both the ILX34-AENWG and the Access Point, and there is a wireless link between these devices, a loop will be formed. Typically the Access Point detects this loop and disconnects the wireless link. In this condition, the link LED on the ILX34-AENWG will periodically come on and then go off. Also, the Wireless Statistics web page will sometimes show the unit is linked and then later show that it is not.

3.2.8 Configure the Application

Create a New RSLogix 5000 Project

Note: The following steps require RSLogix 5000 version 17 or newer, and a processor with firmware compatible with this version of RSLogix 5000. To use the ILX34-AENWG adapter with an earlier version of RSLogix 5000 or the processor firmware, please refer to Using the ILX34-AENWG with Earlier Versions of RSLogix 5000.

- 1 Open the **FILE** menu, and then choose **NEW...**

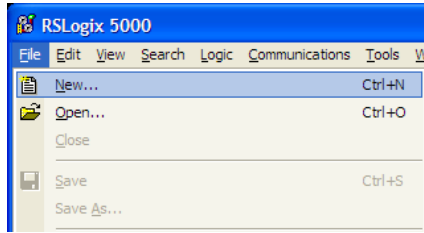

- 2 Select **REVISION 17**.

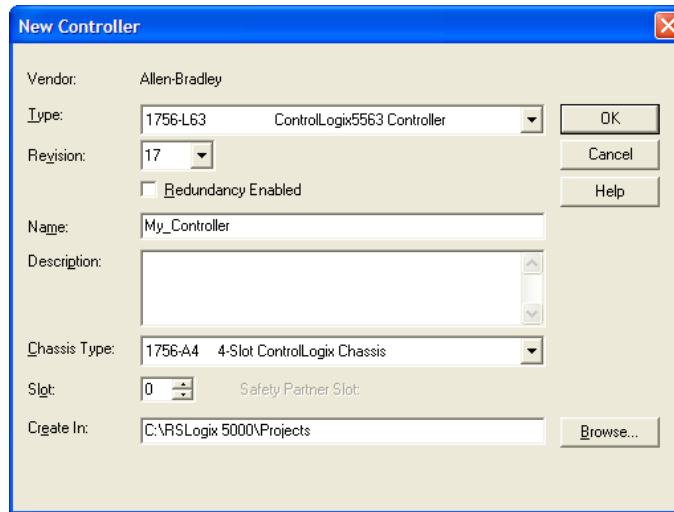

Create the Network

- 1 Right-click **I/O CONFIGURATION** and choose **NEW MODULE...**

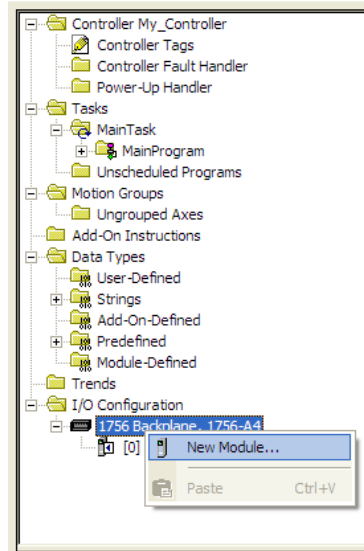

- 2 Expand the **COMMUNICATIONS** node, and then select the **ETHERNET BRIDGE** module that matches your hardware. This example uses a 1756-ENBT/A module.

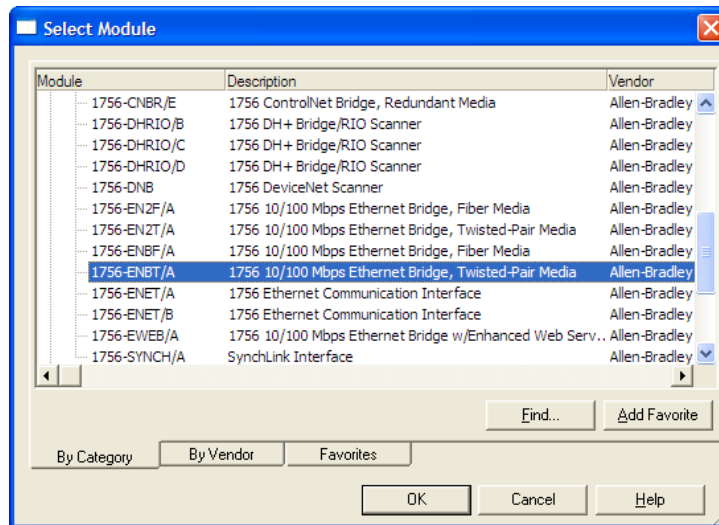

Note: If you are prompted to "Select Major Revision", choose the lower of the available revision numbers.

- 3 Name the ENBT/A module, then set the IP Address and slot location in the local rack with the ControlLogix processor.

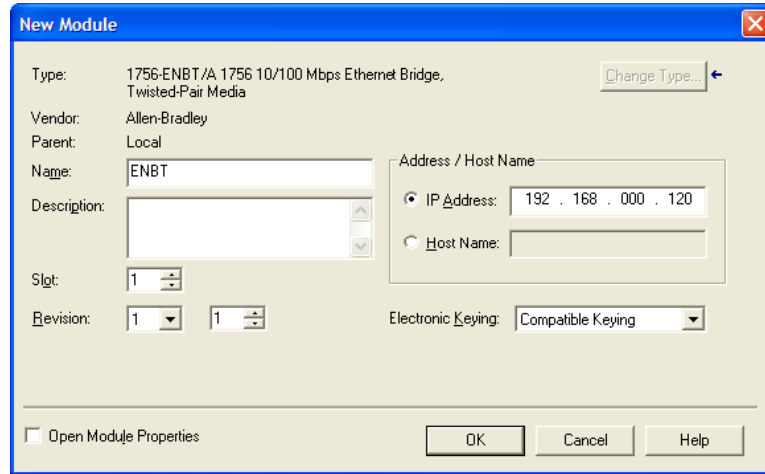

- 4 Click **OK**.

Create the Adapter

- 1 Next, select the **1756-ENBT** module that you just created in the Controller Organization pane and click the right mouse button to open a shortcut menu. On the shortcut menu, choose **NEW MODULE**.

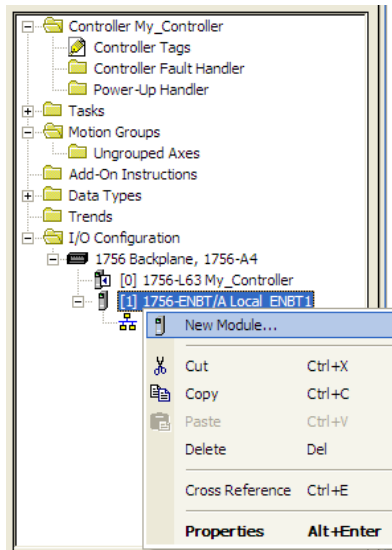

- 2 In the **SELECT MODULE** dialog box, click the **VENDOR** tab, and then expand the **PROSOFT TECHNOLOGY** node. Click the **BY VENDOR** tab, expand the **PROSOFT TECHNOLOGY** node, and then select **ILX34-AENWG**.

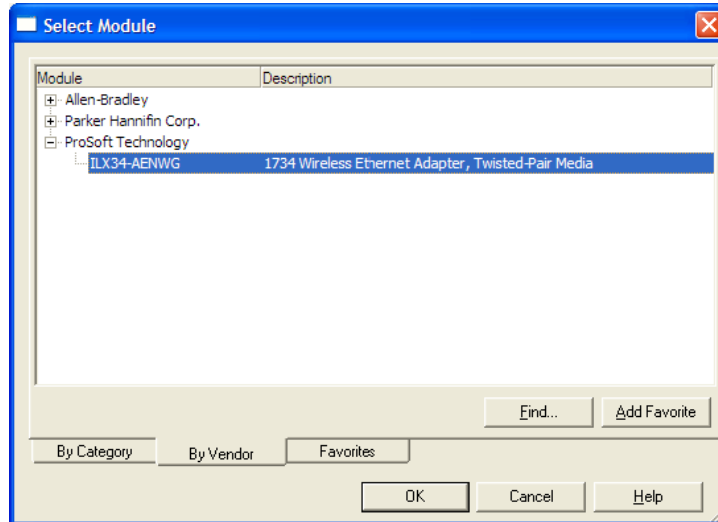

- 3 Name the ILX34-AENWG adapter, and set the IP address.

Important: The IP address on the ILX34-AENWG's thumbwheel switches must match the IP address you enter here.

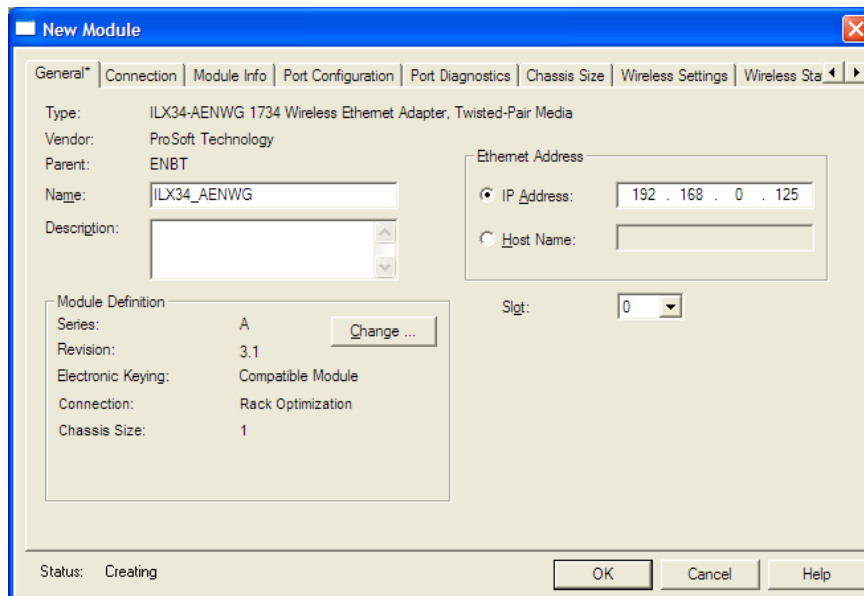

Configure Chassis Size

The ILX34-AENWG requires configuration of its chassis size before you can make any I/O connections. The default setting for the chassis size is 1 slot, which represents the adapter by itself, and allows for no I/O.

You must set the chassis size to a number equaling 1 slot for the adapter plus 1 slot for each I/O module present in the adapter's backplane. For example, the adapter plus 2 I/O modules uses a chassis size of 3. The adapter stores this chassis size setting in non-volatile storage.

When the adapter's non-volatile chassis size does not match the actual number of modules present on its backplane, the adapter does not make any I/O connections and an error occurs.

- 1 In the Module Definition area of the General tab, click the **CHANGE** button. This action opens the **MODULE DEFINITION** dialog box.

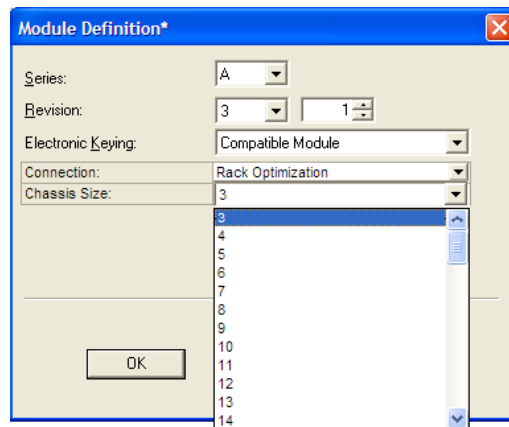

- 2 Select the Chassis Size for your project from the dropdown list, and then Click **OK** to close the **MODULE DEFINITION** dialog box. In a later step, you will verify the chassis size when you are online with the ILX34-AENWG.

3.2.9 Example 1 - Direct Connection and Rack Optimization

This example configures your ILX34-AENWG for both direct connection and rack optimization using RSLogix 5000 software.

You can mix communication formats for different I/O modules communicating through the same adapter.

- I/O modules set up to use rack optimization communicate at the rate of the RPI configured for the ILX34-AENWG adapter.
- I/O modules configured for direct communication communicate at their own set RPI and ignore the ILX34-AENWG adapter RPI.

Attention: You must use series C POINT I/O modules with the ILX34-AENWG adapter. Series A or B POINT I/O modules will not work with this adapter.

Add the Relay Output Module and Configure for Direct Connection

- 1 Right-click the ILX34-AENWG adapter under the I/O Configuration folder and select **NEW MODULE**.

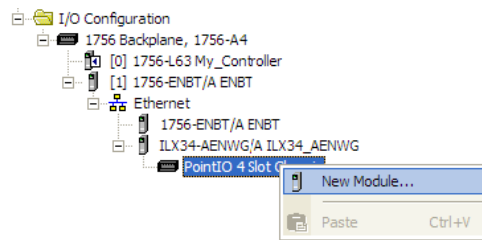

- 2 In the **SELECT MODULE** dialog box, choose the **1734-OW2** relay output module from the list, and click **OK**.

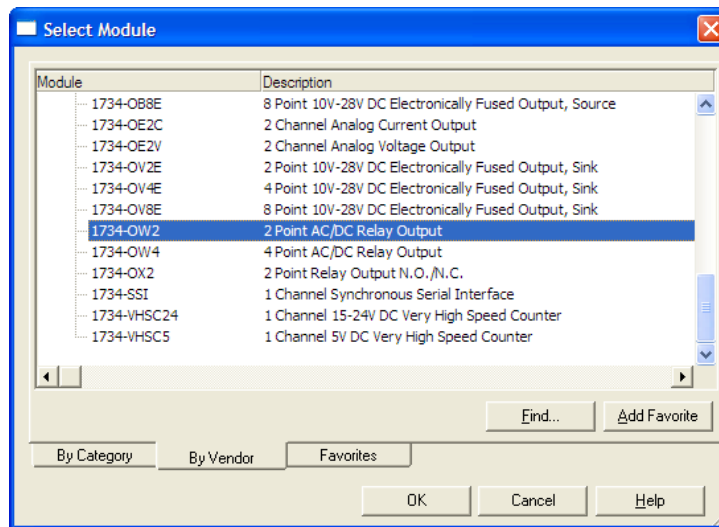

- 3 In the **MODULE PROPERTIES** dialog, enter the following information:
- a) Name
 - b) Slot

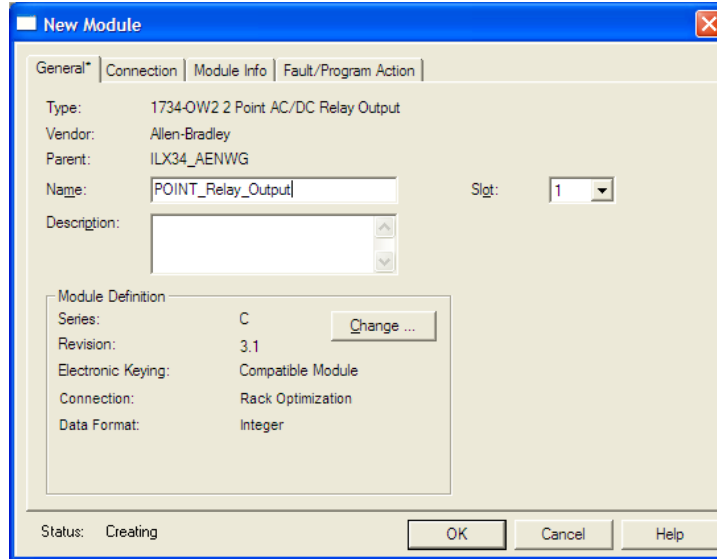

In the Module Definition area, click the **CHANGE ...** button, and change the Connection type from Rack Optimization (default) to **DATA**.

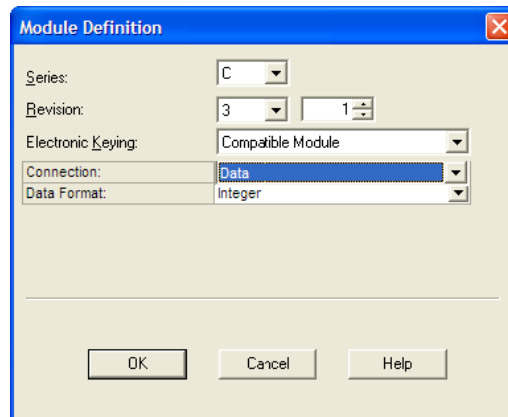

- 4 Click the **CONNECTION** tab, and then change the RPI value for the module from 20 (the default) to 50 (the recommended value for analog or specialty modules). This value determines how often to exchange data with the ILX34-AENWG adapter.

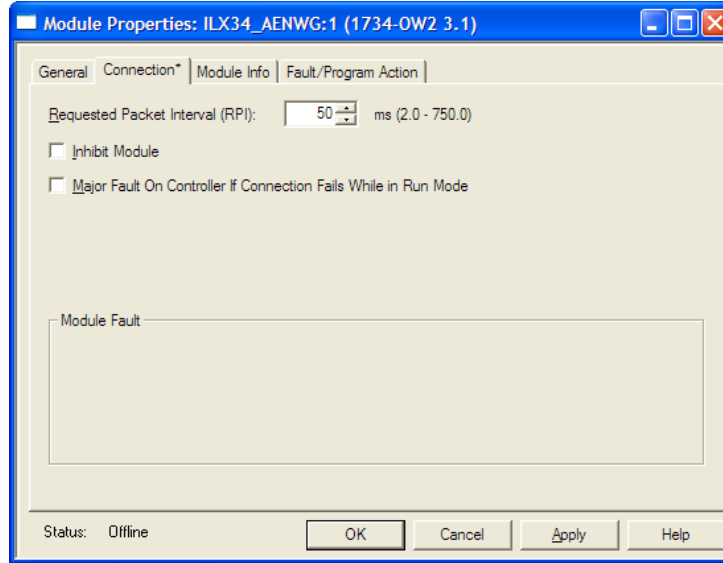

Important: To avoid overloading the ILX34-AENWG adapter, we recommend that RPI be no less than 10 ms for rack connections and 50 ms for direct connections.

- 5 Click **OK** save the configuration.
The following illustration shows the I/O Configuration for this project.

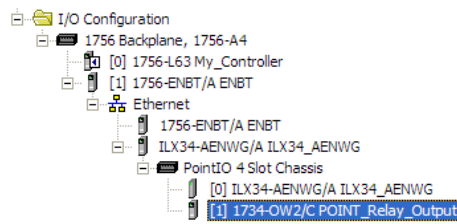

Add the Digital Output Module and Configure for Rack Optimization

- 1 Right-click the ILX34-AENWG adapter under the I/O Configuration folder and select **NEW MODULE**.

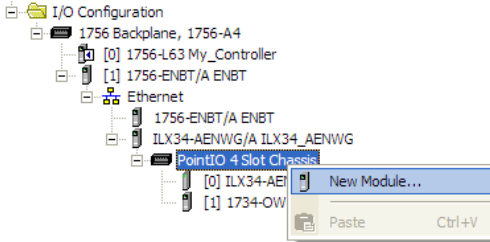

- 2 In the **SELECT MODULE** dialog box, choose the **1734-OV4E** digital output module from the list, and click **OK**.

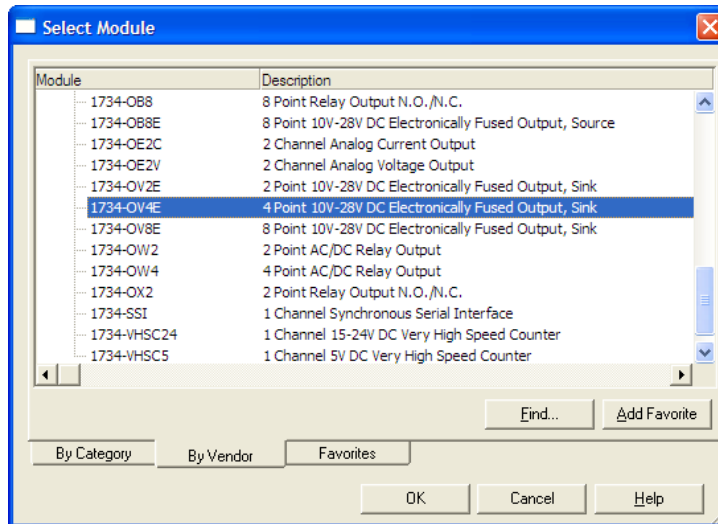

- 3 In the **MODULE PROPERTIES** dialog, enter the following information:
- a) Name
 - b) Slot

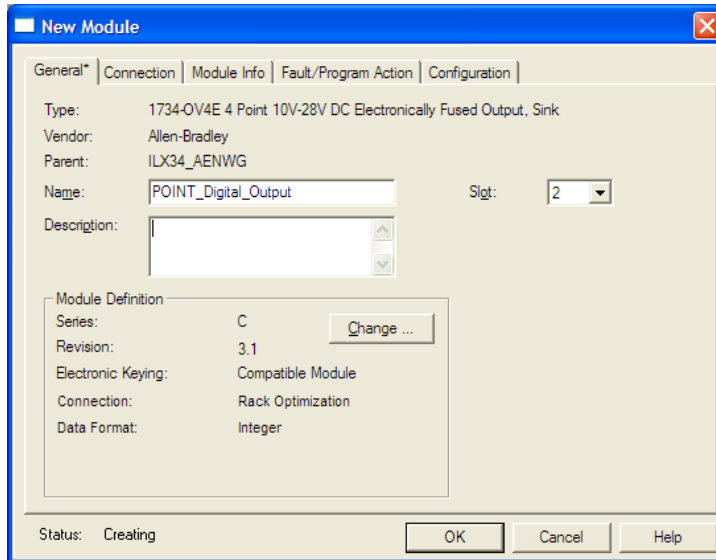

In the **MODULE DEFINITION** area of the dialog box, notice that the default Connection type is **RACK OPTIMIZATION**.

- 4 Click the **CONNECTION** tab, and then change the RPI value for the module from 20 (the default) to 10 (the recommended value for digital modules). This value determines how often to exchange data with the ILX34-AENWG adapter.

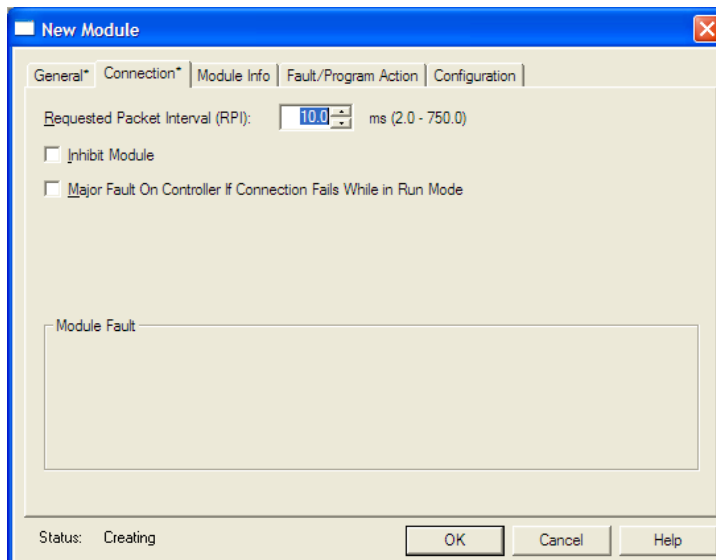

Important: To avoid overloading the ILX34-AENWG adapter, we recommend that RPI be no less than 10 ms for rack connections and 50 ms for direct connections.

- 5 Click **OK** save the configuration.

The following illustration shows the I/O Configuration for this project.

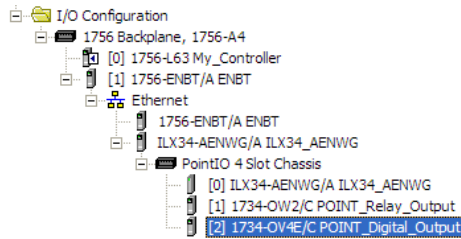

Download the Sample Program to the Processor

Note: The key switch on the front of the ControlLogix processor must be in the REM or PROG position.

- 1 If you are not already online with the processor, open the **COMMUNICATIONS** menu, and then choose **DOWNLOAD**. RSLogix will establish communication with the processor.
- 2 When communication is established, RSLogix will open a confirmation dialog box. Click the **DOWNLOAD** button to transfer the sample program to the processor.

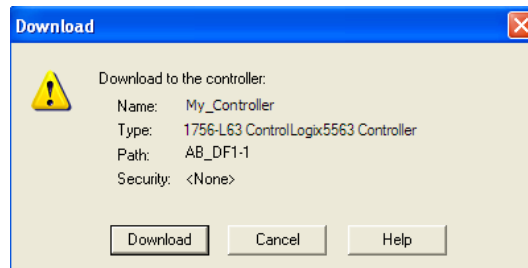

- 3 RSLogix will compile the program and transfer it to the processor. This process may take a few minutes.
- 4 When the download is complete, RSLogix will open another confirmation dialog box. If the keyswitch is in the **REM** position, click **OK** to switch the processor from *Program* mode to *Run* mode.

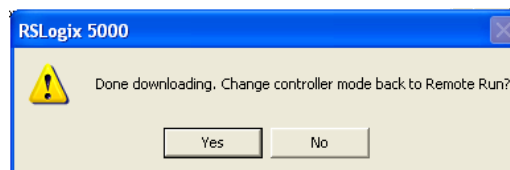

Note: If you receive an error message during these steps, refer to your RSLogix documentation to interpret and correct the error.

Verify the Chassis Size

You must configure the chassis size for the ILX34-AENWG before you can make any I/O connections (page 31). The default setting for the chassis size is 1 slot, which represents the adapter by itself.

When the adapter's non-volatile chassis size does not match the actual number of modules present on its backplane, the adapter does not make any I/O connections and an error occurs, as shown in the **MODULE PROPERTIES** dialog box.

This procedure synchronizes the chassis size value from the RSLogix 5000 software into the ILX34-AENWG hardware. You must be online to perform this procedure.

- 1 Verify that RSLogix 5000 software is online to the processor.
- 2 Double-click the **ILX34-AENWG** adapter under **I/O CONFIGURATION** in the **CONTROLLER ORGANIZATION** window. This action opens the **MODULE PROPERTIES** dialog box.
- 3 On the **MODULE PROPERTIES** dialog box, click the **CONNECTION** tab. Notice that the **MODULE FAULT** area of the dialog box contains information about the error code.

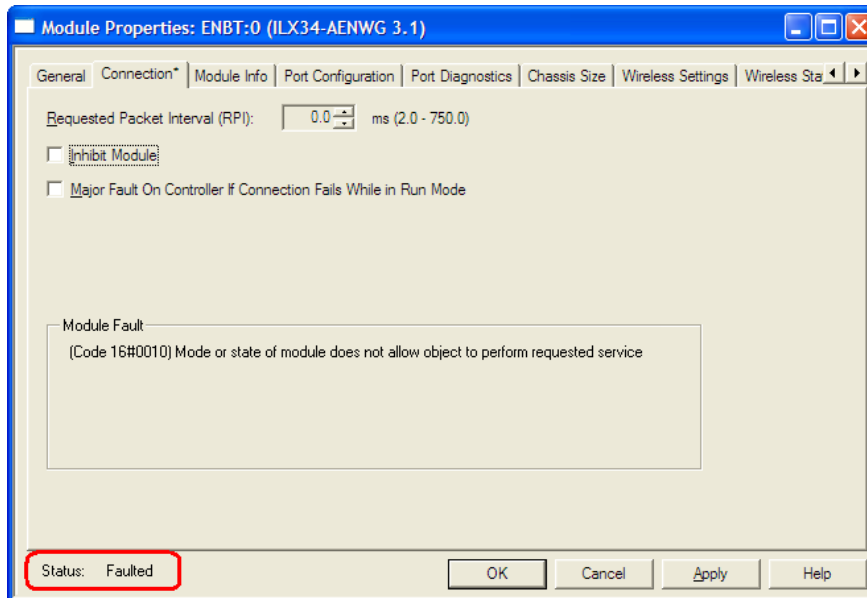

- 4 Click the **CHASSIS SIZE** tab, and then click the **CLICK SET CHASSIS SIZE IN MODULE** button.

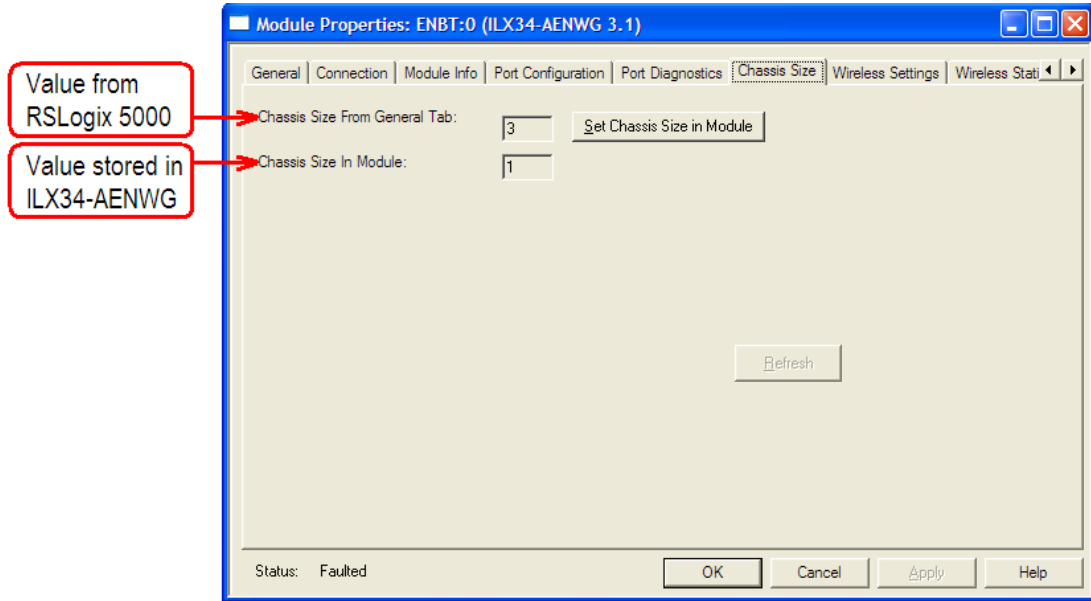

- 5 This action opens a notification dialog box. Take any necessary steps to prevent hazardous conditions, and then click **OK** to dismiss the dialog box.

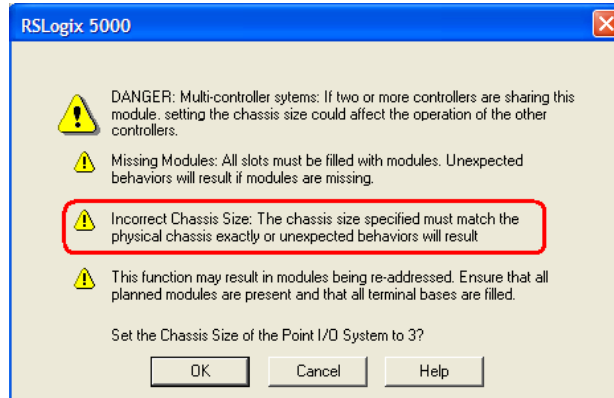

- 6 Notice the chassis size in the module has been updated to match the hardware configuration.

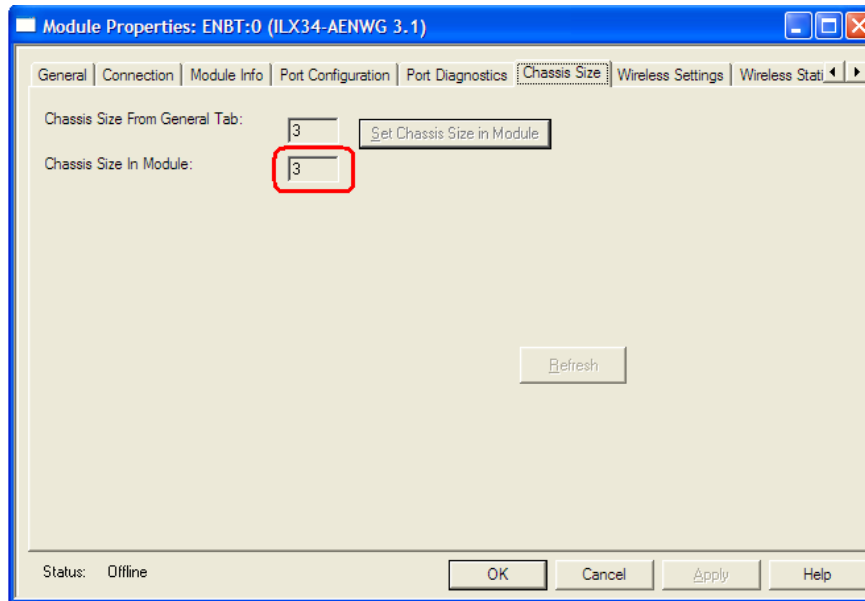

- 7 Click **OK** to dismiss the Module Properties dialog box.

At this point, your POINTBus status LED should be solid green. All the yellow triangles in your I/O configuration should be gone.

- 8 Open the **FILE** menu, and then click **SAVE** to save the project.

View Module Data

You can view module data and communication status in the controller tags in RSLogix 5000. The following illustration shows the ILX34-AENWG configured with the sample application.

- POINT_IO_Adapter = the name you gave to your Ethernet adapter
- # = slot number of POINT I/O module
- C = configuration, I = input, O = output

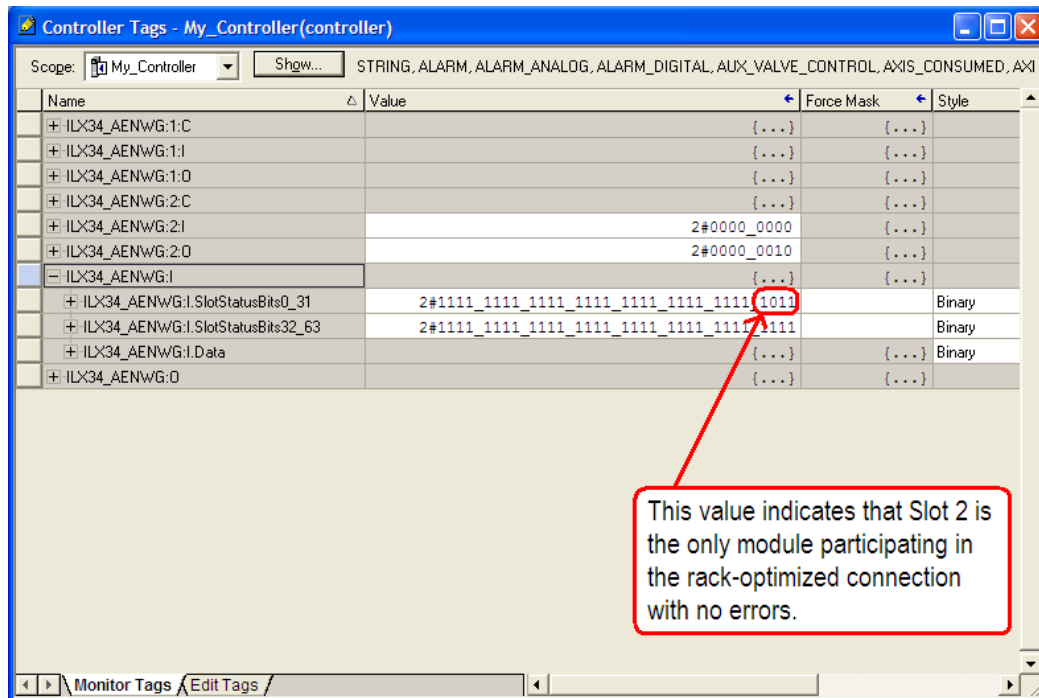

Use the controller tags in your ladder program to read input data or write output data.

- Slot Status Bits: The Slot Status bits display the connection status for each of the POINT I/O modules that use a rack-optimized connection.
- Bit 0 is reserved for the adapter and always reports a value of 1.
- Each of the other bits (1 to 63) correspond to a POINT I/O module that you install in the POINT I/O backplane.
- In this example, we configured the ILX34-AENWG adapter for both rack-optimized and direct connections.
- The slot status bits indicate that the module in slot 2 is operating correctly:
 - 0=module participating with no errors and
 - 1=module not participating or connection error (typically, module removed/missing)

3.2.10 Example 2 - Direct Connection

In this example, a ControlLogix controller communicates with POINT I/O modules via the ILX34-AENWG adapter using a direct connection.

The adapter makes a direct connection to each of the modules referenced by the data.

Attention: You must use series C POINT I/O modules with the ILX34-AENWG adapter. Series A or B POINT I/O modules will not work with this adapter.

Add the Relay Output Module and Configure for Direct Connection

- 1 Right-click the ILX34-AENWG adapter under the I/O Configuration folder and select **NEW MODULE**.

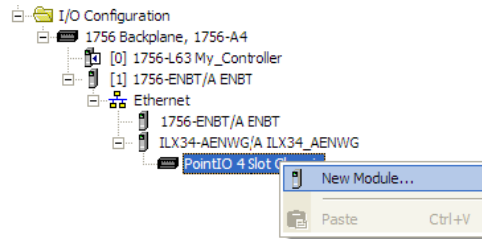

- 2 In the **SELECT MODULE** dialog box, choose the **1734-OW2** relay output module from the list, and click **OK**.

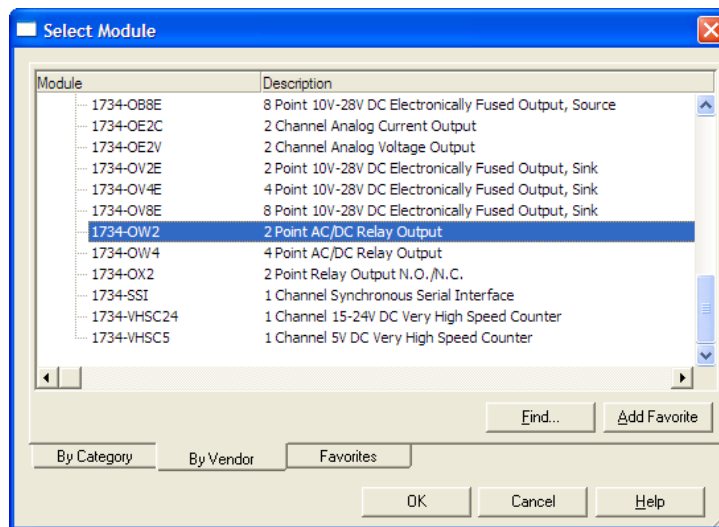

- 3 In the **MODULE PROPERTIES** dialog, enter the following information:
- a) Name
 - b) Slot

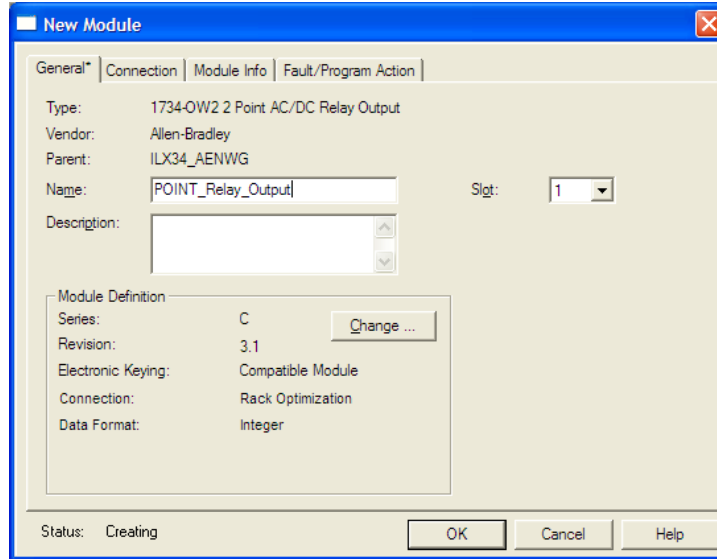

In the Module Definition area, click the **CHANGE ...** button, and change the Connection type from Rack Optimization (default) to **DATA**.

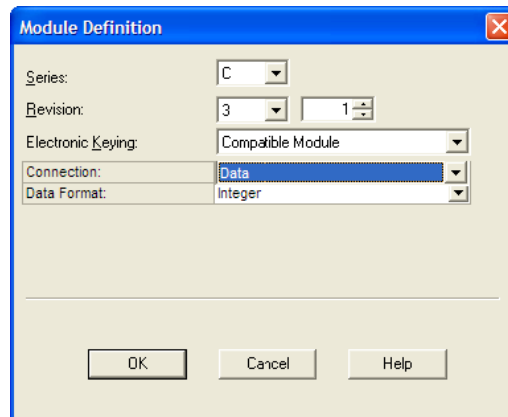

- 4 Click the **CONNECTION** tab, and then change the RPI value for the module from 20 (the default) to 50 (the recommended value for analog or specialty modules). This value determines how often to exchange data with the ILX34-AENWG adapter.

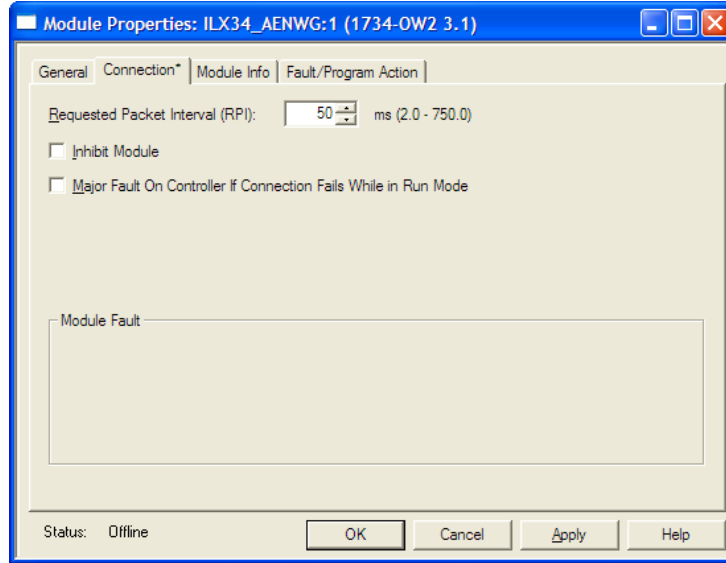

Important: To avoid overloading the ILX34-AENWG adapter, we recommend that RPI be no less than 10 ms for rack connections and 50 ms for direct connections.

- 5 Click **OK** save the configuration.

The following illustration shows the I/O Configuration for this project.

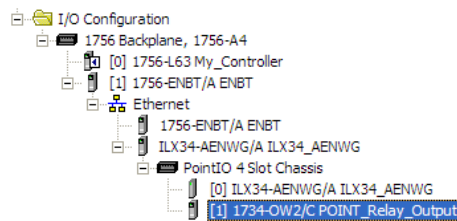

Add the Digital Output Module and Configure for Direct Connection

- 1 Right-click the ILX34-AENWG adapter under the I/O Configuration folder and select **NEW MODULE**.

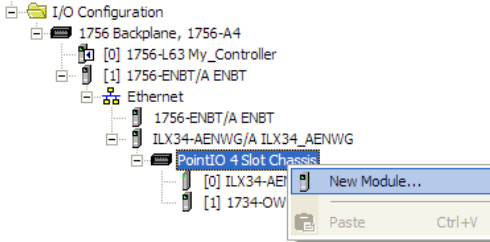

- 2 In the **SELECT MODULE** dialog box, choose the **1734-OV4E** digital output module from the list, and click **OK**.

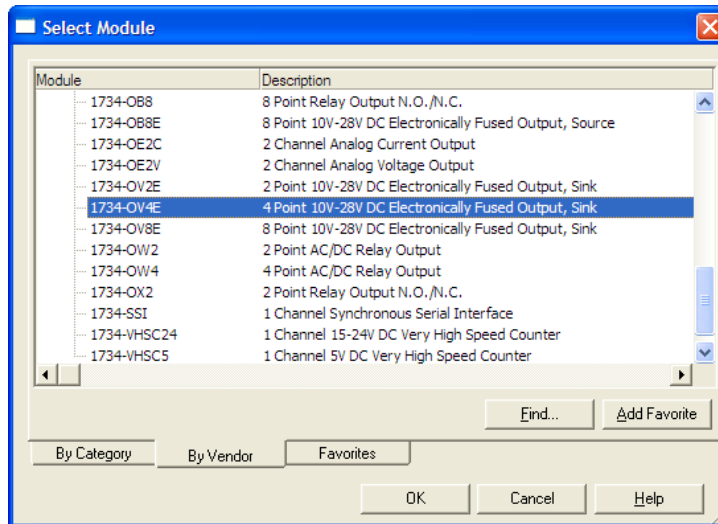

- 3 In the **MODULE PROPERTIES** dialog, enter the following information:
- a) Name
 - b) Slot

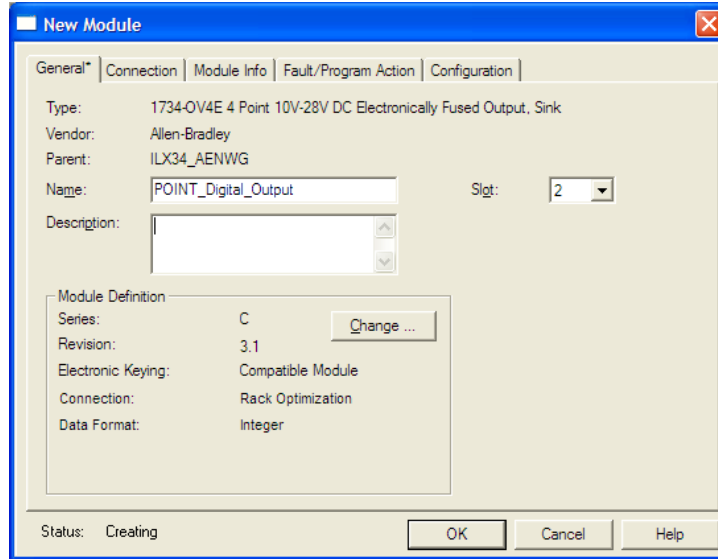

In the Module Definition area, click the **CHANGE ...** button, and change the Connection type from Rack Optimization (default) to **DATA**.

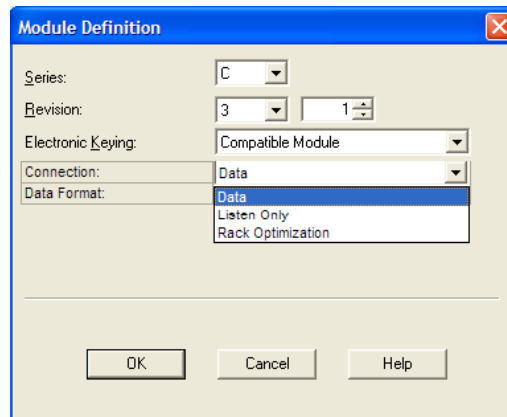

- 4 Click the **CONNECTION** tab, and then change the RPI value for the module from 20 (the default) to 10 (the recommended value for digital modules). This value determines how often to exchange data with the ILX34-AENWG adapter.

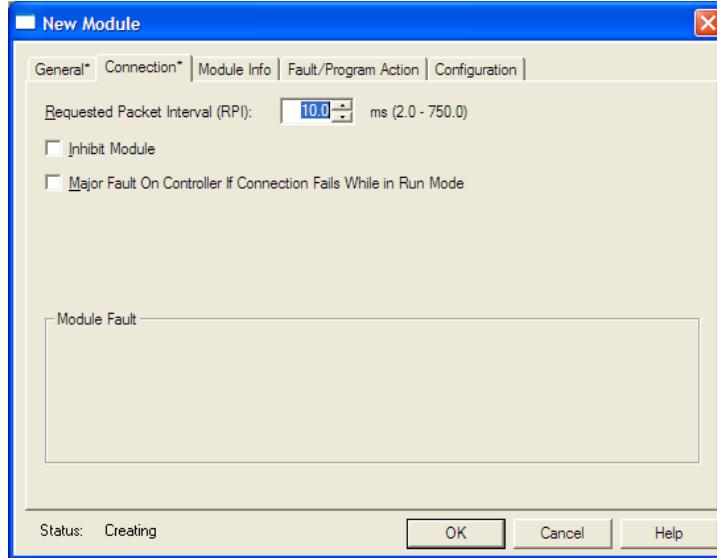

- 5 Click **OK** save the configuration.

The following illustration shows the I/O Configuration for this project.

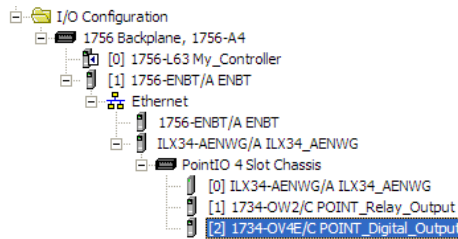

Edit the Controller Tags

When you add modules to the I/O configuration, the system creates tags for those modules to use in the application program.

For the example application, you need to add one more controller tag.

- 1 Double-click the **CONTROLLER TAGS** folder in the project dialog.

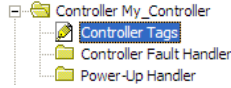

The action opens the **CONTROLLER TAGS** dialog box. You will see the tags created for the ILX34-AENWG adapter and digital I/O modules.

- 2 Click the Edit Tags tab at the bottom of the Controller Tags dialog.

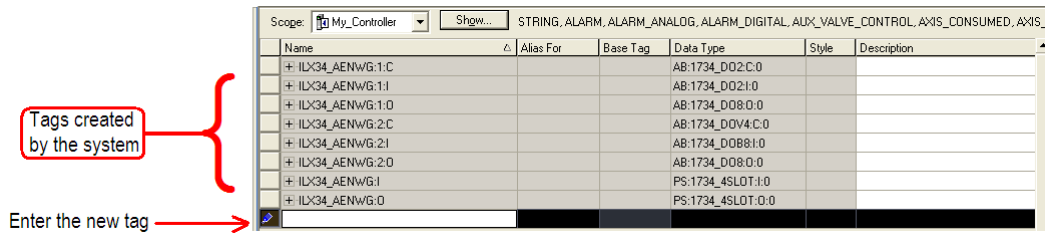

- 3 Create the following tag:

Tag	Type
Parts_Count	Counter

- 4 Close the Controller Tags dialog.

Create the Ladder Program

Next, create the example ladder program to test the I/O.

- 1 Double-click **MAIN ROUTINE** under the Main Program folder.

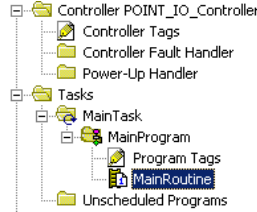

- 2 Enter the following ladder program using the tags previously created.

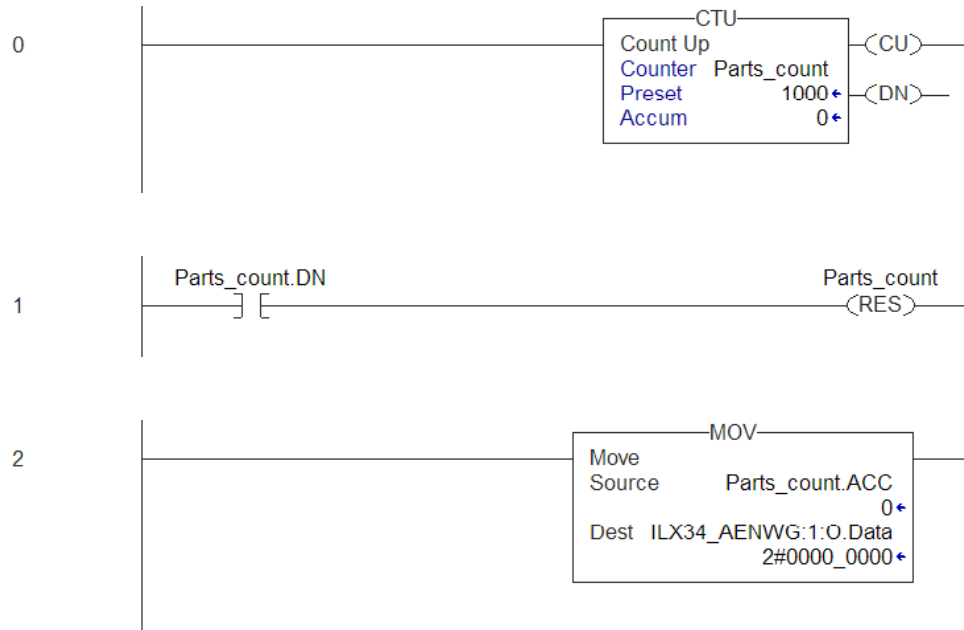

- 3 Save the program.

Download the Sample Program to the Processor

Note: The key switch on the front of the ControlLogix processor must be in the REM or PROG position.

- 1 If you are not already online with the processor, open the **COMMUNICATIONS** menu, and then choose **DOWNLOAD**. RSLogix will establish communication with the processor.
- 2 When communication is established, RSLogix will open a confirmation dialog box. Click the **DOWNLOAD** button to transfer the sample program to the processor.

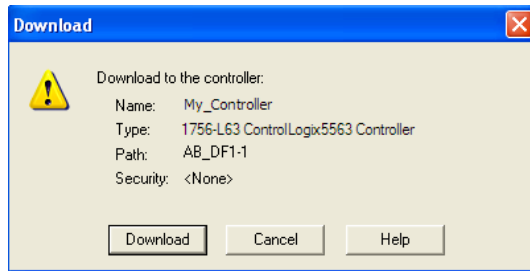

- 3 RSLogix will compile the program and transfer it to the processor. This process may take a few minutes.
- 4 When the download is complete, RSLogix will open another confirmation dialog box. If the keyswitch is in the **REM** position, click **OK** to switch the processor from *Program* mode to *Run* mode.

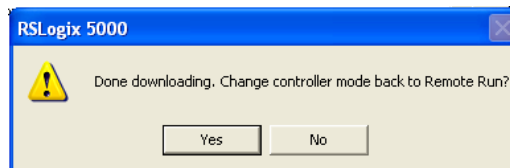

Note: If you receive an error message during these steps, refer to your RSLogix documentation to interpret and correct the error.

Verify the Chassis Size

You must configure the chassis size for the ILX34-AENWG before you can make any I/O connections (page 31). The default setting for the chassis size is 1 slot, which represents the adapter by itself.

When the adapter's non-volatile chassis size does not match the actual number of modules present on its backplane, the adapter does not make any I/O connections and an error occurs, as shown in the **MODULE PROPERTIES** dialog box.

This procedure synchronizes the chassis size value from the RSLogix 5000 software into the ILX34-AENWG hardware. You must be online to perform this procedure.

- 1 Verify that RSLogix 5000 software is online to the processor.
- 2 Double-click the **ILX34-AENWG** adapter under **I/O CONFIGURATION** in the **CONTROLLER ORGANIZATION** window. This action opens the **MODULE PROPERTIES** dialog box.
- 3 On the **MODULE PROPERTIES** dialog box, click the **CONNECTION** tab. Notice that the **MODULE FAULT** area of the dialog box contains information about the error code.

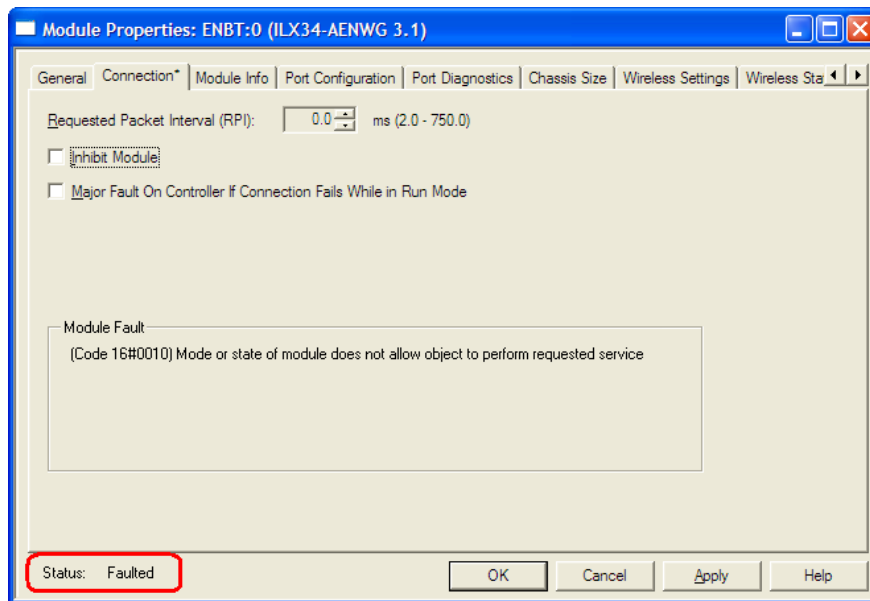

- 4 Click the **CHASSIS SIZE** tab, and then click the **CLICK SET CHASSIS SIZE IN MODULE** button.

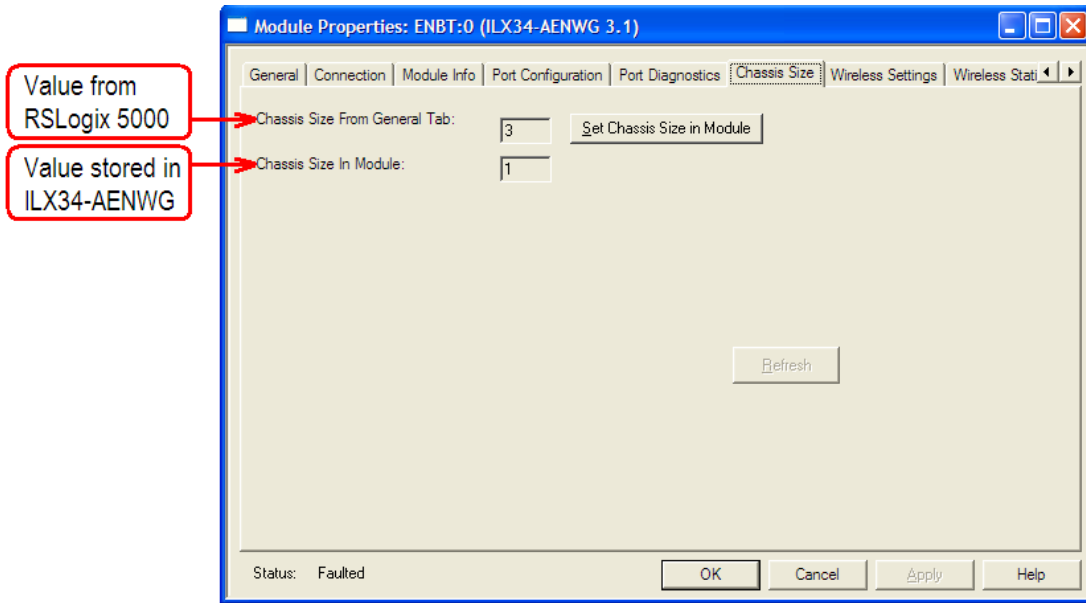

- 5 This action opens a notification dialog box. Take any necessary steps to prevent hazardous conditions, and then click **OK** to dismiss the dialog box.

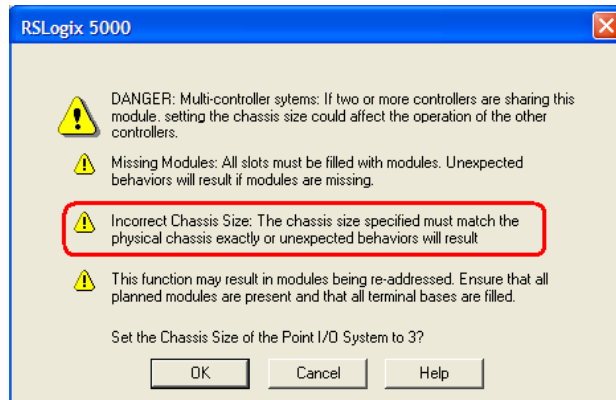

- 6 Notice the chassis size in the module has been updated to match the hardware configuration.

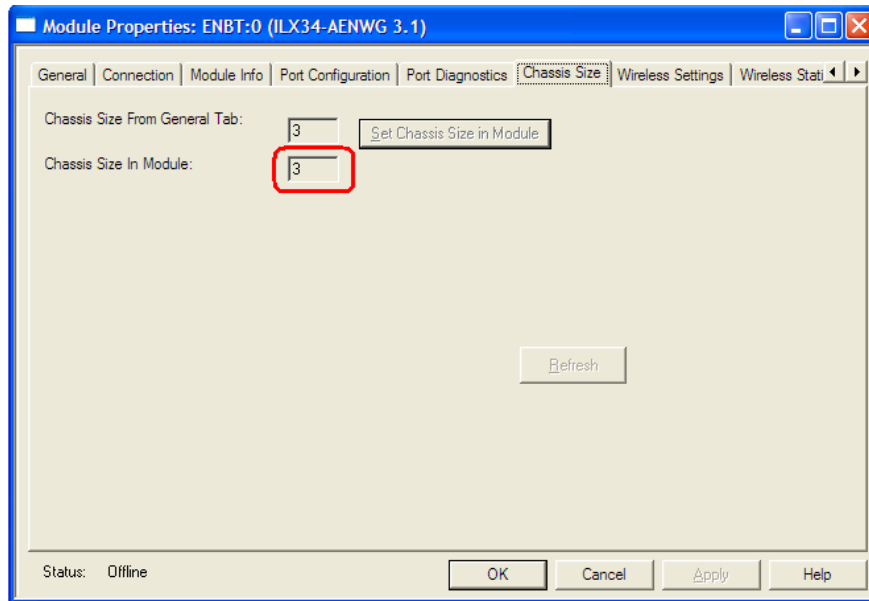

- 7 Click **OK** to dismiss the Module Properties dialog box.

At this point, your POINTBus status LED should be solid green. All the yellow triangles in your I/O configuration should be gone.

- 8 Open the **FILE** menu, and then click **SAVE** to save the project.

View Module Data

You can view module data and communication status in the controller tags in RSLogix 5000. The following illustration shows the ILX34-AENWG configured with the sample application.

- ILX34_AENWG = the name you gave to your Ethernet adapter
- # = slot number of POINT I/O module
- C = configuration, I = input, O = output

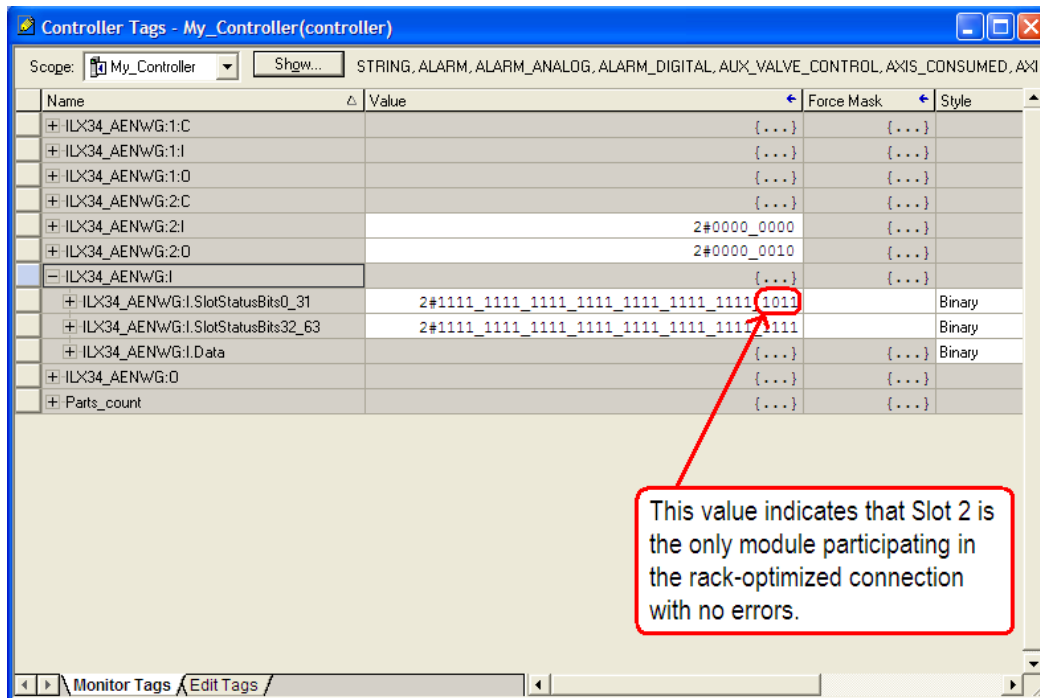

Use the controller tags in your ladder program to read input data or write output data.

- Slot Status Bits: The Slot Status bits display the connection status for each of the POINT I/O modules that use a rack-optimized connection.
- Bit 0 is reserved for the adapter and always reports a value of 1.
- Each of the other bits (1 to 63) correspond to a POINT I/O module that you install in the POINT I/O backplane.
- In this example, we configured the ILX34-AENWG adapter for both rack-optimized and direct connections.
- The slot status bits indicate that the module in slot 2 is operating correctly:
 - 0=module participating with no errors and
 - 1=module not participating or connection error (typically, module removed/missing)

3.3 Verify Communication

3.3.1 Wireless Statistics Page

The **WIRELESS STATISTICS** page opens when you expand the **DIAGNOSTICS** folder, and then click the **WIRELESS STATISTICS** link on the left side of the page. Use this page to view configuration and status information for the Wireless port on the ILX34-AENWG.

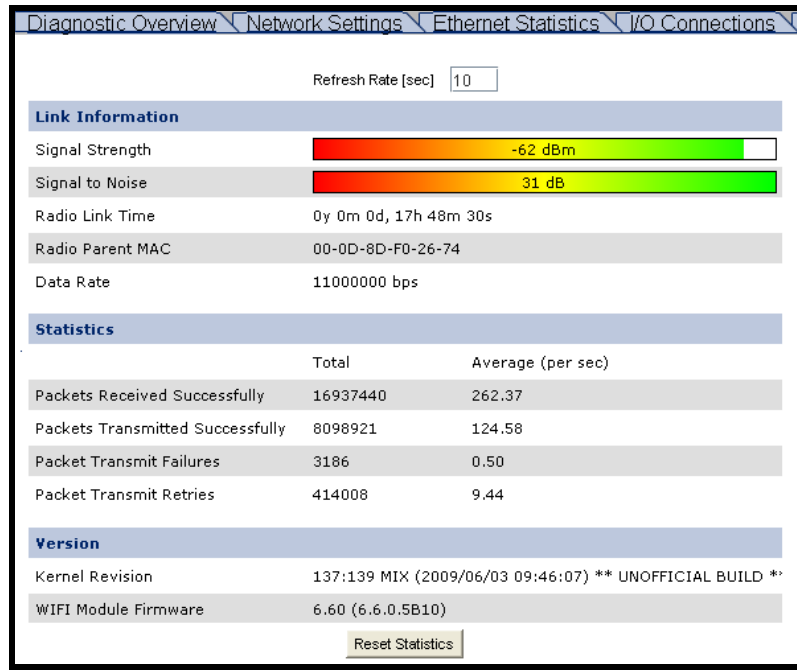

Link Information

Field	Description
Signal Strength	The colored graph indicates the signal level (page 56).
Signal to Noise	<ul style="list-style-type: none"> ▪ < 0 , this is a BAD condition ▪ < 10, this is an OK condition ▪ > 10, this is a GOOD condition
Radio Link Time	<p>The up-link time in days:hours:minutes:seconds.</p> <p>Note: This link status is checked at the Refresh rate, once every 10 seconds by default. If the link is down for less time than this, the up-time for the link will not get reset to 0.</p>
Radio Parent MAC	The MAC address (hexadecimal) of the parent radio (access point)
Data Rate	Rf rate of the last packet received by the ILX34-AENWG. Although this field is informational, some packets, such as 802.11 management packets, will be at a rate that is lower than the data. In such an instance, the data could be going at a rate faster than this.

















Statistics

Field	Description
Packets Received Successfully	Messages received with success. The average value gives a good indication of RF bandwidth consumption. The average should not exceed 1000 packets per second. If it does exceed this, the RPI should be decreased on the connections.
Packets Transmitted Successfully	Messages sent with success. The average value gives a good indication of RF bandwidth consumption. The average should not exceed 500 packets per second. If it does exceed this, the RPI should be decreased on the connections.
Packet Transmit Failures	Messages that have been retried 8 times and still were not transferred successfully. This number should not exceed 1% of the Packets Transmitted successfully.
Packet Transmit Retries	Messages sent requiring a retry. Retries of 20 to 50 per second are not uncommon. Retries of several hundred per second indicate the RF network is too busy or the RF link is poor.

Version

Field	Description
Kernel Revision	The internal software revision for the POINT I/O adapter
WIFI Module Firmware	The internal software revision for the wireless component of the POINT I/O adapter

Signal Strength Graph

Image	Signal Strength	Signal to Noise
	-90 dBm	0 dB
	-88 dBm	2 dB
	-86 dBm	4 dB
	-84 dBm	6 dB
	-82 dBm	8 dB
	-80 dBm	10 dB
	-78 dBm	12 dB
	-76 dBm	14 dB
	-74 dBm	16 dB
	-72 dBm	18 dB
	-70 dBm	20 dB
	-68 dBm	22 dB
	-66 dBm	24 dB
	-64 dBm	26 dB
	-62 dBm	28 dB
	-60 dBm	30 dB

4 Conclusion

In This Chapter

- ❖ How to Get Help 57
- ❖ Frequently Asked Questions 58

4.1 How to Get Help

ProSoft Technology has several ways for customers to acquire knowledge fast! In an all encompassing support page, technical support is now right at your fingertips. Here you get the ProSoft Knowledgebase, a community of experts and experienced end-users on our bulletin board, as well as presentations, one-on-one chat, on the go tutorials and streaming media training.

Knowledgebase: Type a question into our knowledgebase search engine. Answers come from a technical support knowledge database built from helping inquisitive customers like you.

Frequently Asked Questions: If you want to know ProSoft Support's top ten questions asked, just click on our FAQ. Using an FAQ could get you the answers you need immediately. Check back regularly for updates.

Bulletin Board: Here's a public forum just for you. Make comments, ask questions, and get to know ProSoft's automation community. Register, login, and join the discussion.

Live Chat (8am to 5pm PST): Communicate with a Technical Support Engineer online. This is just one more way to get one-on-one support from our knowledgeable support staff.

Downloads: Look no further. Get manuals, datasheets, configuration utilities, and more.

Training: Get help through our online tutorials and streaming media training series.

Contact: You can always call or email with your technical support questions. Also, if you have any comments or suggestions, please let us know.

Go to www.prosoft-technology.com/support (<http://www.prosoft-technology.com/support>) or call +1.661.716.5100

4.2 Frequently Asked Questions

What is the benefit of using ProSoft's RadioLinx Industrial Hotspots vs. third party WLAN access points (APs)?

ProSoft Technology's Industrial Hotspots (RLXIB-IHW and RLXIB-IHG) have been optimized for use with multicast I/O messaging with integrated RF based IGMP querying to learn locations of data consumers and efficiently route traffic to them, saving bandwidth vs. third-party Access Points that would simply broadcast the produced message. In addition, ProSoft Technology's Industrial Hotspots take advantage of the learned consumer locations to unicast the wireless packets, enabling retransmission and fewer dropped data packets.

What is ProSoft Technology's Integrated Wireless Architecture™?

ProSoft Technology's Integrated Wireless Architecture (IWA) refers to the high level of optimization of ProSoft Technology's industrial wireless LAN products for use with Rockwell Automation's Integrated Architecture. Examples include superior handling of multicast producer consumer messaging, use of wireless CIP diagnostic objects, integration of wireless into Rockwell Automation's POINT I/O and ControlLogix® platforms, and using AOPs for RSLogix™ 5000 to configure and monitor ProSoft Technology IWA devices. ProSoft Technology's RadioLinx® Industrial Hotspots provide the IWA infrastructure for chassis-based products like the wireless POINT I/O Adapter (ILX34-AENWG).

Will the ILX34-AENWG communicate with ProSoft Technology's wireless module for ControlLogix (MVI56-WA-EIP)?

The MVI56-WA-EIP module does not support implicit messaging and so does not support the ILX34-AENWG. Instead, use a RadioLinx Industrial Hotspot™ such as RLXIB-IHG or RLXIB-IHW connected to an ENET card or CompactLogix™ Ethernet processor.

What are the minimum firmware and software requirements of my Rockwell Automation® Logix controllers and RSLogix software required to configure the ILX34-AENWG using RSLogix 5000?

Product	Version
RSLogix 5000	v17
RSLinx	v2.54
1756-EN2T	v2.005
1756-ENBT	v4.007
1756-ENET Ser B	v2.7
1756-L6x	v17.03
1756-6xS (Safety PLC)	v17.07
1768-ENBT	v2.003
1769-L32E	v17.04
1769-L35E	v17.04

If I do not have the minimum versions list above, can I still use the ILX34-AENWG?

Yes. Configure wireless parameters using the integrated web pages in the ILX34-AENWG. Configure the I/O modules using the 1734-AENT Add-On Profile.

Can I use the ILX34-AENWG in safety applications? If so, why is it not red like other safety products? What safety level is available?

Rockwell Automation makes safety I/O modules for the POINT I/O platform called POINT Guard I/O™. The safety functionality is in the devices, in this case a GuardLogix™ controller and POINT Guard I/O modules, and it makes no difference whether the connection is wired or wireless provided supported RPI times meet requirements and long enough that nuisance safety trips are avoided. 1734-IB8S - 8 Point Safety Sink Input and 1734-OB8S - 8 Point Safety Source Output are the two POINT Guard I/O modules available today. The ILX34-AENWG passes data through to the POINT Guard I/O modules and thus does not require safety rating and is not red. TÜV Functional safety rated: up to SIL 3, Category 4, performance Level e.

How many ILX34-AENWGs can I use in one network?

There are two limitations to the number of ILX34-AENWGs that may be used in a single network - the number of connections supported by the Rockwell Automation® controller or ENET card and the practical limitation of how long the RPI needs to be to support the required number of connections. For example, the 1756-ENBT and 1756-EN2T Ethernet communications modules support 128 and 256 connections, respectively. If additional connections are required, additional ENET cards may be used. Rack optimization of discrete I/O helps to minimize the number of connections. From a RPI perspective, each connection will increase the minimum RPI time and at some point the RPI may exceed the maximum allowed by the application. If the RPI is too long, the ILX34-AENWG network may be segmented using multiple access points operating on non-overlapping channels.

What if my application requires standalone control or faster sense to actuation time than supported by the minimum RPI time of the ILX34-AENWG (<20 msec)?

Use the DeviceLogix POINT I/O module - 1734-8CFGDLX that can execute "locally" and autonomously up to 124 function blocks or ladder logic.

What diagnostic information is available from the ILX34-AENWG?

Wireless performance statistics may be accessed from the web pages of the ILX34-AENWG, the RSLogix™ 5000 Add-On Profile, or in a HMI software such as FactoryTalk® View using the wireless diagnostic object. Parameters include: firmware number, link time, parent MAC address, parent data rate, average signal level, average noise level, transmit packet successes and failures, receive packet successes and failures, and number of transmit retries.

5 Glossary of Terms

8

802.11

A group of wireless specifications developed by the IEEE. It details a wireless interface between devices to manage packet traffic.

802.11a

Operates in the 5 GHz frequency range with a maximum 54 Mbit/sec signaling rate.

802.11b

Operates in the 2.4 GHz Industrial, Scientific, and Measurement (ISM) band. Provides signaling rates of up to 11 Mbit/sec and is the most commonly used frequency.

802.11g

Similar to 802.11b but supports signaling rates of up to 54 Mbit/sec. Operates in the heavily used 2.4 GHz ISM band but uses a different radio technology to boost throughput.

802.11i

Sometimes Wi-Fi Protected Access 2 (WPA 2). WPA 2 supports the 128-bit and above advanced encryption Standard, along with 802.1x authentication and key management features.

802.11n

Designed to raise effective WLAN throughput to more than 100 Mbit/sec.

802.11s

Deals with mesh networking.

A

Access Point

A generic term for an 802.11 radio that "attaches" other 802.11 radios (clients) to a wired network. APs can also bridge to one another.

Ad hoc Mode

Wireless network framework in which devices can communicate directly with one another without using an AP or a connection to a regular network.

AES

Advanced Encryption Standard. New standard for encryption adopted by the U.S. government for secure communications.

Amplifier

A device connected to an antenna used to increase the signal strength and amplify weak incoming signals.

Antenna

A device connected to a wireless transceiver that concentrates transmitted and received radio waves to increase signal strength and thus the effective range of a wireless network.

ASCII

American Standard Code for Information Interchange. A communication mode in which each eight-bit byte in a message contains one ASCII character code. ASCII characters (or hexadecimal characters) are sometimes used as a key to encrypt data and ensure its secure transmission.

Association

Process whereby two 802.11 radios establish communications with each other. Requirements for communication include common SSID (network names) and encryption settings.

Authenticate

The process of confirming the identity of someone connecting to a network.

Authentication Server

A back-end database server that confirms the identity of a supplicant to an authenticator in an 802.1x-authenticated network.

B

Band

Another term for spectrum used to indicate a particular set of frequencies. Wireless networking protocols work in either the 2.4 GHz or the 5 GHz bands.

Bandwidth

(See Throughput)

Base Station

See Wireless Gateway

Baud Rate

The speed of communication between devices on the network. All devices must communicate at the same rate.

BootP

BootP (Bootstrap Protocol) is a low-level protocol that provides configurations to other nodes on a TCP/IP network. BootP configuration files let you automatically assign IP addresses to an Ethernet module (you can also obtain subnet masks and gateway addresses from BootP).

bps

Bits per Second. A measure of data transmission speed across a network or communications channel; bps is the number of bits that can be sent or received per second.

Bridge

A node between two similar communication subnets where protocol translation is minimal.

C

Channel

One portion of the available radio spectrum that all devices on a wireless network use to communicate. Changing the channel on the access point/router can help reduce interference.

CIP

Control and information protocol, the EtherNet/IP application layer uses the producer/consumer networking model. In this model one producer broadcasts (multicasts) the data once to all the consumers. All consumers see the data simultaneously and may choose whether to consume (receive) the data or not. Delivery time is consistent, no matter how many consumers there are.

Client

A client is software program, or the device on which that program runs, that makes requests for information from a software program, or the device on which that program runs, in a client-server relationship.

A Client on an Ethernet network is equivalent to a Master on a serial network.

Configuration PC

A Computer that contains the configuration tools for the ILX34-AENWG.

Connection

The communication mechanism from the controller to another module in the control system, usually used to exchange I/O data.

consumer

A destination device in the CIP networking model. See CIP.

CSMA/CD

Carrier sense multiple access/collision detection is the access method used in Ethernet. When a device wants to gain access to the network, it checks to see if the network is quiet (senses the carrier). If it is not, it waits a random amount of time before retrying. If the network is quiet and two devices access the line at exactly the same time, their signals collide. When the collision is detected, they both back off and each waits a random amount of time before retrying.

D

dB_i

Decibels referenced to an "ideal" isotropic radiator in free space; frequently used to express antenna gain

dB_m

Decibels referenced to one milliwatt (mW); an "absolute" unit used to measure signal power (transmit power output or received signal strength)

DCE

Data communications equipment. A modem, for example.

Decibel (dB)

A measure of the ratio between two signal levels; used to express gain (or loss) in a system.

Default Gateway

The IP address of a network router where data is sent if the destination IP address is outside the local subnet. The gateway is the device that routes the traffic from the local area network to other networks such as the Internet.

Determinism

The ability to predict when information will be delivered. Important in time-critical applications.

DHCP

The dynamic host configuration protocol is an Internet protocol, similar to BootP, for automating the configuration of computers that use TCP/IP. DHCP can be used to automatically assign IP addresses, to deliver IP stack configuration parameters, such as the subnet mask and default router, and to provide other configuration information, such as the addresses for printer, time, and news servers.

Direct Sequence Spread Spectrum

One of two approaches (with frequency hopping spread spectrum) for sorting out overlapping data signals transmitted via radio waves. 802.11b uses DSSS

Directional Antenna

Transmits and receives radio waves off the front of the antenna.

Diversity Antenna

An antenna system that uses multiple antennas to reduce interference and maximize reception and transmission quality.

DNS

The domain name system is a hierarchical, distributed method of organizing the name space of the Internet. The DNS administratively groups hosts into a hierarchy of authority that allows addressing and other information to be widely distributed and maintained. A big advantage to the DNS is that using it eliminates dependence on a centrally-maintained file that maps host names to addresses.

DTE

Data Terminal Equipment, for example, a computer or terminal.

Dual Band

A device that is capable of operating in two frequencies. On a wireless network, dual-band devices are capable of operating in both the 2.4 GHz (802.11b/g) and 5 GHz (802.11a) bands.

E

EAP

Extensible Authentication Protocol. A protocol that provides an authentication framework for both wireless and wired Ethernet enterprise networks.

EIRP

Equivalent isotropically radiated power (EIRP) is the amount of power that would have to be emitted by an isotropic antenna (that evenly distributes power in all directions and is a theoretical construct) to produce the peak power density observed in the direction of maximum antenna gain.

Encryption

Method of scrambling data so that only the intended viewers can decipher and understand it.

ESD

Electrostatic Discharge. Can cause internal circuit damage to the coprocessor.

ESSID

Extended Service Set Identifier. A name used to identify a wireless network.

Ethernet

A physical layer standard using carrier sense multiple access with collision detection (CSMA/CD) methods.

Ethernet network

A local area network designed for the high-speed exchange of information between computers and related devices.

EtherNet/IP

Ethernet industrial protocol applies a common application layer (CIP) over Ethernet by encapsulating messages in TCP/UDP/IP.

Explicit messaging

Non-time critical messaging used for device configuration and data collection, such as downloading programs or peer-to-peer messaging between two PLC units.

F

Firmware

Firmware is the embedded software code that runs in the module to direct module function (similar to the BIOS in a personal computer). This is distinguished from the Setup/Diagnostic Application software that is installed on the Configuration PC.

Frequency Hopping

A radio that rapidly changes its operating frequency several times per second following a pre-determined sequence of frequencies. The transmitting and receiving radios are programmed to follow the same frequency hopping sequence.

Frequency Hopping Spread Spectrum

Changes or hops frequencies in pattern known to both sender and receiver. FHSS is little influenced by radio stations, reflections, or other environmental factors. However, it is much slower than DSSS.

Fresnel Zone

An elliptical area on either side of the straight line of sight that must also be clear for a long-range wireless network to work.

Full-Duplex

A communications circuit or system designed to simultaneously transmit and receive two different streams of data. Telephones are an example of a full-duplex communication system. Both parties on a telephone conversation can talk and listen at the same time. If both talk at the same time, their two signals are not corrupted.

Fully qualified domain name

A fully qualified domain name (FQDN) is a domain name that includes all higher level domains relevant to the entity named. If you think of the DNS as a tree-structure with each node having its own label, a fully qualified domain name for a specific node would be its label followed by the labels of all the other nodes between it and the root of the tree. For example, for a host, a FQDN would include the string that identifies the particular host, plus all domains of which the host is a part, up to and including the top-level domain (the root domain is always null). For example, PARIS.NISC.SRI.COM is a fully qualified domain name for the host at 192.33.33.109.

G

Gain

The amount by which an antenna concentrates signal strength in a wireless network.

Gateway

In wireless terms, a gateway is an access point with additional software capabilities such as providing NAT and DHCP.

H

Half-Duplex

A communications circuit or system designed to transmit and receive data, but not both simultaneously. CB or walkie-talkie radios are an example of a half-duplex communication system. Either parties on a radio conversation may talk or listen; but both cannot talk at the same time without corrupting each other's signal. If one operator is "talking", the other must be "listening" to have successful communication.

Hardware address

Each Ethernet device has a unique hardware address (sometimes called a MAC address) that is 48 bits. The address appears as six digits separated by colons (such as, xx:xx:xx:xx:xx:xx). Each digit has a value between 0 and 255 (0x00 to 0xFF). This address is assigned in the hardware and cannot be changed. The hardware address is required to identify the device if you are using a BOOTP utility.

Host name

The host name is the unique name for a computer within its domain. This is always the first element of a full name, and, with its domain and top-level domain suffix, creates the unique name of that computer on the Internet. For example, the URL for a trading web site is www.trading.com. The host name is www, which is not unique on the web, but is unique within the trading domain.

The host name can also refer to the fully qualified domain name (FQDN), or in this example, www.trading.com. Both naming methods seem to be used interchangeably in various documents. For the purposes of this document, the host name will refer to the FQDN, or as in this example, www.trading.com.

Hub

A central connecting device that joins devices together in a star configuration. Hubs are generally not suitable for use in I/O control systems, since they are time-critical applications that cannot tolerate lost packets.

Hz

Hertz. The international unit for measuring frequency equivalent to the older unit of cycles per second. One megahertz (MHz) is one million hertz. One gigahertz (GHz) is one billion hertz. The standard US electrical power frequency is 60 Hz. 802.11a devices operate in the 5 GHz band; 802.11b and g devices operate in the 2.4 GHz band.

I

IEEE

Institute of Electrical and Electronics Engineers, Inc. IEEE is a professional organization with members in over 175 countries and is an authority in technical areas such as computer engineering and telecommunications. IEEE developed the 802.11 specifications.

Implicit messaging

Real-time messaging of I/O data.

IP

Internet protocol that provides the routing mechanism for messages. All messages contain not only the address of the destination station, but the address of a destination network, which allows messages to be sent to multiple networks within an organization or around the world.

IP Address

A 32-bit identification number for each node on an Internet Protocol network. These addresses are represented as four sets of 8-bit numbers (numbers from 0 to 255), with decimals between them. Networks using the TCP/IP Protocol route messages based on the IP address of the destination. Each number can be 0 to 255. For example, 192.168.0.100 could be an IP address. Each node on the network must have a unique IP address.

K

Key

A set of information (often 40 to as much as 256 bits) that is used as a seed to an encryption algorithm to encrypt (scramble) data. Ideally, the key must also be known by the receiver to decrypt the data.

L

LAN

A system of connecting PCs and other devices within the same physical proximity for sharing resources such as internet connections, printers, files, and drives. When Wi-Fi is used to connect the devices, the system is known as a wireless LAN or WLAN.

Latency

The time between initiating a request for data and the beginning of the actual data transfer.

LED

Light-emitting diode.

Line of Sight (LoS)

A clear line from one antenna to another in a long-range wireless network.

M

MAC ID

Media Access Control address. Every 802.11 device has its own MAC address. This is a unique identifier used to provide security for wireless networks. When a network uses a MAC table, only the 802.11 radios that have had their MAC addresses added to the network's MAC table are able to get on the network.

Master device

Device that is connected to the Master radio.

Mbps

Megabits per second, or millions of bits per second. A measure of bandwidth.

Megahertz

A measure of electromagnetic wave frequency equal to one million hertz. Often abbreviated as MHz and used to specify the radio frequency used by wireless devices.

Mesh Networking

Features free standing, non wired network nodes that communicate among one another and form self-configuring networks, with only one node required to hook into a wired LAN. The other nodes are simply plugged into an electrical outlet, so cabling is much less of an issue.

MIMO

Multiple Input Multiple Output refers to using multiple antennas in a WiFi device to improve performance and throughput. MIMO technology takes advantage of a characteristic called multipath, which occurs when a radio transmission starts out at Point A and the reflects off or passes through surfaces or objects before arriving, via multiple paths, at Point B. MIMO technology uses multiple antennas to collect and organize signals arriving via these paths.

Multicast

In the CIP producer/consumer model, one producer multicasts (broadcasts) the data once to all the consumers.

N

Network

A series of stations or nodes connected by some type of communication medium. A network may consist of a single link or multiple links.

Node

An address or software location on the network.

P

Panel Antenna

An antenna type that radiates in only a specific direction. Panel antennas are commonly used for point-to-point situations. Sometimes called Patch antennas.

Parabolic Antenna

An antenna type that radiates a very narrow beam in a specific direction. Parabolic antennas offer the highest gain for long-range point-to-point situations.

Poll

A method of electronic communication.

Power Supply

Device that supplies electrical power to the I/O chassis containing the processor, coprocessor, or other modules.

Producer

The source of information in the CIP networking model. See CIP.

Protocol

The language or packaging of information that is transmitted between nodes on a network.

Q

QoS

Quality of Service. Required to support wireless multimedia applications and advanced traffic management. QoS enables Wi-Fi access points to prioritize traffic and optimize the way shared network resources are allocated among different applications.

R

Rack-optimized

A physical and logical collection of application modules.

RADIUS

Remote Access Dial-In Service. This describes a general method for allowing remote users access to a network. It authenticates the user, specifies passwords and access rights to network resources. It also keeps track of accounting for when and how long the user is logged onto the network. It was originally used for dial-in users, accessing corporate networks via modems. It is now being specified as part of the 802.11i standard to control access of users to wireless networks. Any of several protocols can be used by the wireless client to communicate with the RADIUS server to gain access to the network resources. These protocols include EAP-TLS (Windows), LEAP (Cisco) and EAP-TTLS.

Range

The distance covered by a wireless network radio device. Depending on the environment and the type of antenna used, Wi-Fi signals can have a range of up to a mile.

Remote Access Point

One of a number of secondary access points in a wireless network that uses WDS to extend its range. Remote access points (sometimes called relay access points) connect to a master access point.

Remote device

Devices connected remote radios

Repeater

A Repeater is a device used to extend the range of a Wi-Fi signal. Placed at the edge of signal reception, a repeater simply receives and re-transmits the signal.

S

Sector Antenna

An antenna type that radiates in only a specific direction. Multiple sector antennas are commonly used in point-to-multipoint situations.

Signal Diversity

A process by which two small dipole antennas are used to send and receive, combining their results for better effect.

Signal Loss

The amount of signal strength that's lost in antenna cable, connectors, and free space. Signal loss is measured in decibels. Also referred to as gain loss.

Signal Strength

The strength of the radio waves in a wireless network.

Simplex

A communications circuit or system designed to either transmit data or receive data, but not both. Broadcast television is an example of simplex communication system. A television station sends a TV signal but cannot receive responses back from the television sets to which it is transmitting. The TV sets can receive the signal from the TV station but cannot transmit back to the station.

Site Survey

A comprehensive facility study performed by network managers to ensure that planned service levels will be met when a new wireless LAN, or additional WLAN segments to an existing network are deployed. Site survey's are usually performed by a radio frequency engineer and used by systems integrators to identify the optimum placement of access points to ensure that planned levels of service are met. Site surveys are sometimes conducted following the deployment to ensure that the WLAN is achieving the necessary level of coverage. Site surveys can also be used to detect rogue access points.

Spectrum

A range of electromagnetic frequencies.

Spread Spectrum

A form of wireless communication in which a signal's frequency is deliberately varied. This increases bandwidth and lessens the chances of interruption or interception of the transmitted signal.

SSI

Service Set Identifier is a sequence of characters unique to a specific network or network segment that's used by the network and all attached devices to identify themselves and allow devices to connect to the correct network when one or more than one independent network is operating in nearby areas.

Subnet Mask

A mask used to determine what subnet an IP address belongs to. An IP address has two components: the network address, and the host (node or device) address. For example, consider the IP address 150.215.017.009. Assuming this is part of a Class B network (with a subnet mask of 255.255.0.0), the first two numbers (150.215) represent the Class B network address, and the second two numbers (017.009) identify a particular host on this network.

Switch

A network device that cross connects devices or network segments. A switch provides each sender/receiver the full network bandwidth (2x in full duplex mode), reduces collisions, and increases determinism.

T

TCP

The transport control protocol is a more reliable but slower transport protocol than UDP. It is used for explicit (not time critical) messaging in EtherNet/IP.

TCP/IP

The transmission control protocol/internet protocol is a transport-layer protocol (TCP) and a network-layer protocol (IP) commonly used for communication within networks and across internetworks.

Transaction

An exchange of request and data and response and data.

U

UART

Universal Asynchronous Receiver/Transmitter

UDP

The user datagram protocol (UDP) is a transport protocol that provides a very simple but fast capability to send datagrams between two devices. It is used for I/O (implicit) messaging in EtherNet/IP.

W

WAP

Wireless Application Protocol. A set of standards to enable wireless devices to access internet services, such as the World Wide Web and email.

WDS

Wireless Distribution System. Enables access points to communicate with one another in order to extend the range of a wireless networks. Used in 802.11g based access points.

WEP

Wired-Equivalent Privacy protocol was specified in the IEEE 802.11 standard to provide a WLAN with a minimal level of security and privacy comparable to a typical wired LAN, using data encryption.

Wi-Fi

A certification mark managed by a trade group called the Wi-Fi Alliance. Wi-Fi certification encompasses numerous standards including 802.11a, 802.11b, 802.11g, WPA, and more. Equipment must pass compatibility testing to receive the Wi-Fi mark.

Wi-Fi CERTIFIED™

The certification standard designating IEEE 802.11-based wireless local area network (WLAN) products that have passed interoperability testing requirements developed and governed by the Wi-Fi alliance.

Wi-Fi Interoperability Certificate

A statement that a product has passed interoperability testing and will work with other Wi-Fi CERTIFIED products.

Wi-Fi Protected Setup

Wi-Fi Protected Setup™ (previously called Wi-Fi Simple Config) is an optional certification program developed by the Wi-Fi alliance designed to ease set up of security enabled Wi-Fi networks in the home and small office environment. Wi-Fi Protected Setup supports methods (pushing a button or entering a PIN into a wizard-type application) that are familiar to most consumers to configure a network and enable security.

Wireless Gateway

Term used to differentiate between an access point and a more-capable device that can share an internet connection, serve DHCP, and bridge between wired and wireless networks.

Wireless Network

Devices connected to a network using a centralized wireless access point.

WLAN

Wireless Local Area Network. A type of local area network in which data is sent and received via high-frequency radio waves rather than cables or wires.

WPA

Wi-Fi Protected Access is a data encryption specification for 802.11 wireless networks that replaces the weaker WEP. It improves on WEP by using dynamic keys, Extensible Authentication Protocol to secure network access, and an encryption method called Temporal Key Integrity Protocol (TKIP) to secure data transmissions.

WPA2

An enhanced version of WPA. It is the official 802.11i standard. It uses Advanced Encryption Standard instead of TKIP. AES supports 128-bit, 192-bit, and 256-bit encryption keys.

Y

Yagi Antenna

An antenna type that radiates in only a specific direction. Yagi antennas are used in point-to-point situations.

Index

8

802.11 • 61
802.11a • 61
802.11b • 61
802.11g • 61
802.11i • 61
802.11n • 61
802.11s • 61

A

About the Example Applications • 9, 13, 14
Access Point • 61
Ad hoc Mode • 61
Adapter Components • 16
Add the Digital Output Module and Configure for Direct Connection • 45
Add the Digital Output Module and Configure for Rack Optimization • 35
Add the Relay Output Module and Configure for Direct Connection • 32, 42
AES • 62
Agency Approval & Certification • 3
Amplifier • 62
Antenna • 62
ASCII • 62
Association • 62
Authenticate • 62
Authentication Server • 62

B

Band • 62
Bandwidth • 62
Base Station • 62
Baud Rate • 62
BootP • 63
bps • 63
Bridge • 63

C

Channel • 63
CIP • 63
Client • 63
Conclusion • 57
Configuration PC • 63
Configure Chassis Size • 31, 38, 51
Configure One or More Repeaters (Optional) • 19
Configure the Application • 9, 27
Configure the ILX34-AENWG for Wireless Access • 23
Configure the IP Address with the Thumbwheel Switches • 20
Configure the Master Radio (Required) • 18

Configure the Wireless Access Point • 10, 18, 23
Configuring Wireless Settings from the Adapter's Web Page • 23
Connect Power to the Adapter • 21
Connect the Adapter to the EtherNet/IP Network • 22
Connection • 63
consumer • 63
Create a New RSLogix 5000 Project • 27
Create the Adapter • 29
Create the Ladder Program • 49
Create the Network • 28
CSMA/CD • 64

D

dBi • 64
dBm • 64
DCE • 64
Decibel (dB) • 64
Default Gateway • 64
Determinism • 64
DHCP • 64
Direct Sequence Spread Spectrum • 64
Directional Antenna • 65
Diversity Antenna • 65
DNS • 65
Download the Sample Program to the Processor • 9, 37, 50
DTE • 65
Dual Band • 65

E

EAP • 65
Edit the Controller Tags • 48
EIRP • 65
Encryption • 65
ESD • 65
ESSID • 65
Ethernet • 65
Ethernet network • 66
EtherNet/IP • 66
European Hazardous Location Approval • 4
Example 1 - Direct Connection and Rack Optimization • 32
Example 2 - Direct Connection • 42
Explicit messaging • 66

F

Firmware • 66
Frequency Hopping • 66
Frequency Hopping Spread Spectrum • 66
Frequently Asked Questions • 58
Fresnel Zone • 66
Full-Duplex • 66
Fully qualified domain name • 67

G

Gain • 67
Gateway • 67

H	Protocol • 70	Q
Half-Duplex • 67		QoS • 71
Hardware address • 67		R
Host name • 67		Rack-optimized • 71
How to Get Help • 57		RADIUS • 71
Hub • 68		Range • 71
Hz • 68		Remote Access Point • 71
		Remote device • 71
I		Repeater • 71
IEEE • 68		S
Implicit messaging • 68		Scope • 9
Important Installation Instructions		Sector Antenna • 71
Radio Modules • 3		Set Up the Hardware • 14
Important User Information • 2		Signal Diversity • 72
Install the Configuration Tools • 15		Signal Loss • 72
Install the ILX34-AENWG Add-On Profile • 9, 15		Signal Strength • 72
Install the Wireless Point I/O Adapter on the DIN-rail • 17		Signal Strength Graph • 55, 56
IP • 68		Simplex • 72
IP Address • 68		Site Survey • 72
		Spectrum • 72
K		Spread Spectrum • 72
Key • 68		SSI • 72
		Subnet Mask • 73
L		Switch • 73
LAN • 69		System Components • 14
Latency • 69		System Requirements • 10, 15
Learning Objectives • 9		T
LED • 69		TCP • 73
Line of Sight (LoS) • 69		TCP/IP • 73
		Transaction • 73
M		U
MAC ID • 69		UART • 73
Master device • 69		UDP • 73
Mbps • 69		V
Megahertz • 69		Verify Communication • 55
Mesh Networking • 69		Verify the Chassis Size • 38, 51
MIMO • 70		Verify Wireless Communication • 26
Multicast • 70		View Module Data • 9, 41, 54
		W
N		WAP • 73
Network • 70		WDS • 73
Node • 70		WEP • 74
North American Hazardous Location Approval • 4		Wi-Fi • 74
		Wi-Fi CERTIFIED™ • 74
P		Wi-Fi Interoperability Certificate • 74
Panel Antenna • 70		Wi-Fi Protected Setup • 74
Parabolic Antenna • 70		Wireless Gateway • 74
Physical Setup • 9, 16		Wireless Network • 74
Pinouts • 2, 21		Wireless Statistics Page • 55
Poll • 70		
Power Supply • 70		
Prerequisites • 10		
Procedures • 15		
Producer • 70		
ProSoft Technology Documentation • 9		
ProSoft Technology® Product Documentation • 5		

WLAN • 74
WPA • 74
WPA2 • 75

Y

Yagi Antenna • 75
Your Feedback Please • 5